

Rotary Measuring Technology

Absolute encoders, Multiturn, SSI/BISS

Sendix absolut, Multiturn Type 5863 (Shaft) / 5883 (Hollow shaft), SSI/BISS

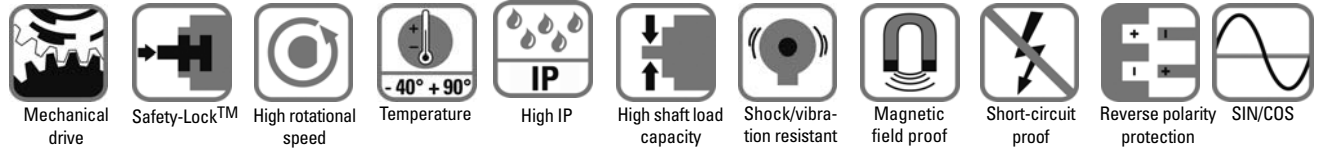

Reliable

- **Increased ability to withstand vibration and installation errors. Eliminates machine downtime and repairs.**
Sturdy "Safety-Lock™ Design" bearing structure
- **Fewer components and connection points increase the operational reliability**
OptoASIC technology with highest integration density (Chip-on-Board)
- **Remains sealed, even in the roughest environments, ensures highest safety against field breakdowns**
Resistant die cast housing and protection up to IP 67
- **Can be used in a wide temperature range without additional expense**
Wide temperature range
- **Easy diagnosis in case of fault condition**
Status indication by means of LED, sensor, voltage and temperature monitoring.



Sendix® absolut

Fast

- **Can achieve particularly high accuracy in the applications**
Update rate of the whole position value above 100 kHz
- **Allows high productivity thanks to very short regulation cycles**
Clock rate with SSI up to 2 MHz, with BiSS up to 10 MHz
- **High-resolution feedback system achievable in real-time**
SinCos incremental outputs.

Versatile

- **The suitable connection variant for every specific case**
Cable, M23 connector or M12 connector
- **Open interfaces ensure flexibility and independence**
SSI or BiSS with Sine-Cosine-Option
- **Reliable installation in a wide diversity of mounting application**
Comprehensive and proven mounting possibilities
- **Only the functionality really needed by the user is implemented**
Status LED and Set key available as options
- **Quick, simple on-site start-up**
Set key or Preset by means of a control input.
- also available in **seawater resistant** version, certified acc. to salt-spray test IEC 68-2-11 => 672 hours.

Mechanical characteristics:

Shaft version:	
Max. speed without shaft seal (IP 65) up to 70 °C:	12 000 min ⁻¹ , continuous 10 000 min ⁻¹
Max. speed without shaft seal (IP 65) up to Tmax:	8 000 min ⁻¹ , continuous 5 000 min ⁻¹
Max. speed with shaft seal (IP 67) up to 70 °C:	11 000 min ⁻¹ , continuous 9 000 min ⁻¹
Max. speed with shaft seal (IP 67) up to Tmax:	8 000 min ⁻¹ , continuous 5 000 min ⁻¹
Hollow shaft version:	
Max. speed without shaft seal (IP 65) up to 70 °C:	9 000 min ⁻¹ , continuous 6 000 min ⁻¹
Max. speed without shaft seal (IP 65) up to Tmax:	6 000 min ⁻¹ , continuous 3 000 min ⁻¹
Max. speed with shaft seal (IP 67) up to 70 °C:	8 000 min ⁻¹ , continuous 4 000 min ⁻¹
Max. speed with shaft seal (IP 67) up to Tmax:	4 000 min ⁻¹ , continuous 2 000 min ⁻¹
Starting torque without shaft seal (IP 65):	Shaft version: < 0.01 Nm Hollow shaft version: < 0.03 Nm
Starting torque with shaft seal (IP 67):	< 0.05 Nm
Moment of inertia:	Shaft version: 4.0 x 10 ⁻⁶ kgm ² Hollow shaft version: 7.0 x 10 ⁻⁶ kgm ²
Radial load capacity of shaft:	80 N
Axial load capacity of shaft:	40 N
Weight:	approx. 0.45 kg
Protection acc. to EN 60 529:	housing: IP 67, shaft: IP 65, opt. IP 67
EX approval for hazardous areas:	optional zone 2 and 22
Working temperature:	-40° C ... +90 °C ¹⁾

¹⁾ Cable versions: -30 °C ... + 75°C

Rotary Measuring Technology

Absolute encoders, Multiturn, SSI/BiSS

Sendix absolut, Multiturn Type 5863 (Shaft) / 5883 (Hollow shaft), SSI/BiSS

Materials:	Shaft: stainless steel, Flange: aluminium, Housing: die cast zinc, Cable: PVC
Shock resistance acc. to DIN-IEC 68-2-27:	>2500 m/s ² , 6 ms
Vibration resistance acc. to DIN-IEC 68-2-6:	>100 m/s ² , 55 ... 2000 Hz

General electrical characteristics:

Supply voltage:	5 V DC ± 5% or 10 ... 30 V DC
Current consumption (w/o output load):	5 V DC: max. 75 mA, 24 V DC: max. 25 mA
Reverse polarity protection at power supply (Ub):	Yes (only 10 ... 30 V DC)
UL certified	File 224618
Conforms to CE requirements acc. to EN 61000-6-2, EN 61000-6-4 and EN 61000-6-3	
RoHS compliant acc. to EU guideline 2002/95/EG	

General Interface characteristics:

Output driver:	RS 485 Transceiver type
Permissible load/channel:	max. ± 20 mA
Signal level high:	typ. 3.8 V
Signal level low at I _{load} = 20 mA:	typ. 1.3 V
Short circuit proof outputs:	Yes ²⁾

Interface characteristics SSI:

Singleturn resolution:	10...14 bits and 17 bits ³⁾
Number of revolutions:	4096 (12 bits)
Code:	Binary or Gray
SSI clock rate:	≤ 14 bits: 50 kHz ... 2 MHz > 15 bis: 50 kHz ... 125 kHz
Monoflop time:	≥ 15 µs ³⁾
Note:	If clock starts cycling within monoflop time a second data transfer starts with the same data, useful for data verification. If clock starts cycling after monoflop time the data transfer starts with updated values. Max. update rate is depending on clock speed, data length and monoflop-time.
Time jitter (data request to position latch):	< 1 µs up to 14 bits, 4 µs at 15 ... 17 bits
Status and Parity bit:	optional on request

Interface characteristics BiSS:

Singleturn resolution:	10...14 bits and 17 bits, customer programmable ³⁾
Number of revolutions:	4096 (12 bits)
Code:	Binary
Clock rate:	up to 10 MHz
Max. update rate:	< 10 µs, depending on clock speed and data length
Time jitter (data request to position latch):	≤ 1 µs
Note:	– Bidirectional, programmable parameters are: resolution, code, direction, alarms and warnings – Multicycle data output, e.g. for temperature – CRC data verification

²⁾ Short circuit to 0V or to output, one channel at a time, supply voltage correctly applied

³⁾ Other options upon request

SET (zero or defined value)

and DIRrection (CW/CCW) control inputs

Input characteristics:	High active
Receiver type:	Comparator
Signal level high:	min. 60 % of V+ (Supply voltage), max: V+
Signal level low:	max. 25% of V+ (Supply voltage)
Input current:	≤ 0.5 mA
Min. pulse duration (SET):	10 ms
Timeout after SET input:	14 ms
Reaction Time (DIR input):	1 ms

The encoder can be set to zero at any position by means of a HIGH signal on the SET input or by pressing the optional SET key. Other preset values can be factory-programmed. The SET input has a signal delay time of approx. 1 ms. Once the SET function has been triggered, the encoder requires an internal processing time of approx. 15 ms before the new position data can be read. During this time the LED is ON and the status output is at LOW.

Status output and LED

Output driver:	Open collector, internal pull up resistor 22 kOhm
Permissible load:	-20 mA
Signal level high:	+V
Signal level low:	< 1 V
Active at:	Low

The optional LED (red) and the status output serve to display various alarm or error messages. In normal operation the LED is OFF and the status output is HIGH (open-collector with int. pull-up 22k).

If the LED is ON (status output LOW) this indicates:

- Sensor error, singleturn or multiturn (soiling, glass breakage etc.)
- LED error, failure or ageing
- Over- or under-temperature
- Undervoltage

In the SSI mode, the fault indication can only be reset by switching off the power-supply to the device.

DIR input

A HIGH signal switches the direction of rotation from the default CW to CCW. This inverted function can also be factory-programmed. If DIR is changed when the device is already switched on, then this will be interpreted as an error. The LED will come ON and the status output will switch to LOW.

Option incremental output (A/B), 2048 ppr

-3dB frequency:	400 kHz
Signal level:	1 V _{pp} (± 20%)
Short circuit proof:	Yes ²⁾

Power-on delay

After Power-ON the device requires a time of approx. 150 ms before valid data can be read.

Rotary Measuring Technology

Absolute encoders, Multiturn, SSI/BiSS

Sendix absolut, Multiturn Type 5863 (Shaft) / 5883 (Hollow shaft), SSI/BiSS

Terminal assignment:

for output circuit 1 or 2 and type of connection 1, 2, 3 or 4 (2 control inputs, 1 status output)

Signal:	GND	+V	+C	-C	+D	-D	SET	DIR	Stat	N/C	N/C	N/C	PE
Cable colour:	WH	BN	GN	YE	GY	PK	BU	RD	BK	-	-	-	Shield
M23 PIN out:	1	2	3	4	5	6	7	8	9	10	11	12	PH

for output circuit 5 and type of connection 1, 2, 3 or 4 (2 control inputs, 1 status output, sensor outputs for voltage)

Signal:	GND	+V	+C	-C	+D	-D	SET	DIR	Stat	N/C	0 V Sens	+Ub Sens	PE
Cable colour:	WH	BN	GN	YE	GY	PK	BU	RD	BK	-	GY-PK	RD-BU	Shield
M23 PIN out:	1	2	3	4	5	6	7	8	9	10	11	12	PH

for output circuit 3, 4, 7 or 8 and type of connection 1, 2, 3 or 4 (2 control inputs, incremental track RS422 or sine/cosine)

Signal:	GND	+V	+C	-C	+D	-D	SET	DIR	A	A inv	B	B inv	PE
Cable colour:	WH	BN	GN	YE	GY	PK	BU	RD	BK	VT	GY-PK	RD-BU	Shield
M23 PIN out:	1	2	3	4	5	6	7	8	9	10	11	12	PH

for output circuit 6 or 9 and type of connection 1, 2, 3 or 4 (Sine/cosine or incremental track, voltage sense outputs)

Signal:	GND	+V	+C	-C	+D	-D	A	A inv	B	B inv	0V Sens	+Ub Sens	PE
Cable colour:	WH	BN	GN	YE	GY	PK	BU	RD	BK	VT	GY-PK	RD-BU	Shield
M23 PIN out:	1	2	3	4	5	6	7	8	9	10	11	12	PH

for output circuit 1 or 2 and type of connection 5 or 6 (2 control inputs)

Signal:	GND	+V	+C	-C	+D	-D	SET	DIR	Shield/PE
M12 PIN out:	1	2	3	4	5	6	7	8	PH

+V: Encoder Power Supply +V DC

GND: Encoder Power Supply Ground (0V)

+C, -C: Clock signal

+D, -D: Data signal

SET: Set input. The current position becomes defined as position zero

DIR: Direction input: If this input is active, output values are decreasing when shaft is turned clockwise.

Stat: Status output

PE: Protective earth

PH: Plug housing (shield)

A, Ainv: Sine output (incremental)

B, Binv: Cosine output (incremental)



Encoder with tangential cable outlet

Top view of mating side, male contact base:

Type	8 pin M12 connector	12 pin M23 connector
View		
Corresponding mating connector:	05.CMB-8181-0	8.0000.5012.0000



- Absolutely safe operation even in strong magnetic fields
- Over 40 years of experience in the field of precision mechanics
- Special gears with specific toothing

Rotary Measuring Technology

Absolute encoders, Multiturn, SSI/BiSS

Sendix absolut, Multiturn Type 5863 (Shaft) / 5883 (Hollow shaft), SSI/BiSS

Dimensions shaft version:

Synchro flange

ø 58 mm, M12, M23 connector, cable versions
Flange type 2 and 4 (Drawing with M12 connector)

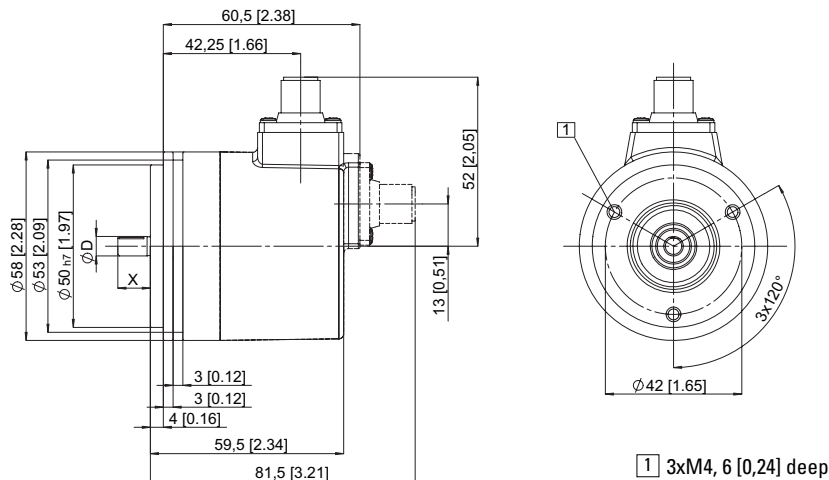

Clamping flange

ø 58 mm, M12, M23 connector, cable versions
Flange type 1 and 3 (Drawing with M23 connector)

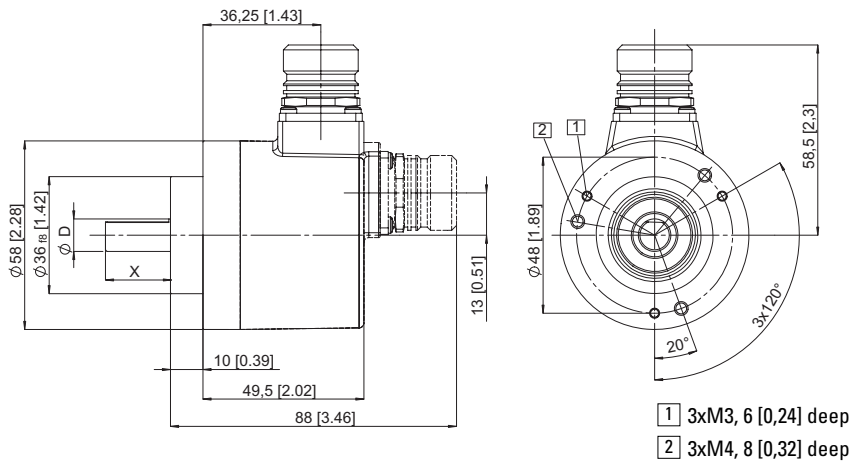

Square flange

63.5 mm □, M12, M23 connector, cable versions
Flange type 5 and 7 (Drawing with cable version)

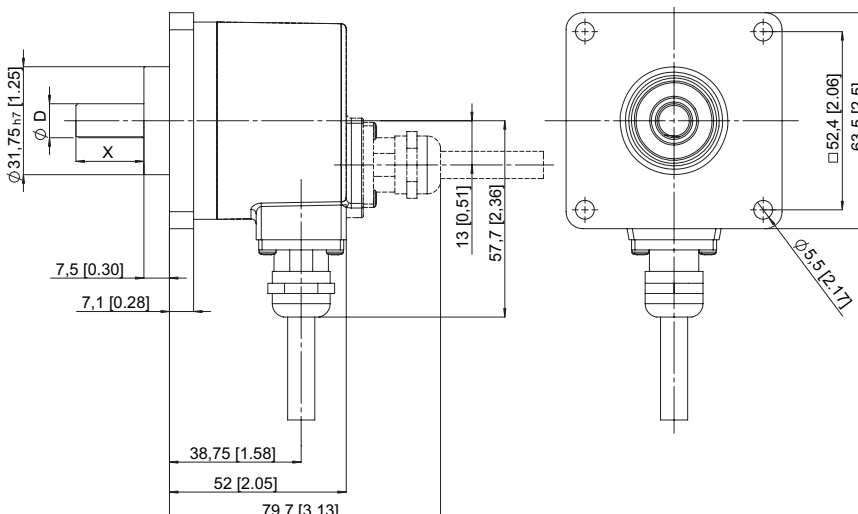

Rotary Measuring Technology

Absolute encoders, Multiturn, SSI/BiSS

Sendix absolut, Multiturn Type 5863 (Shaft) / 5883 (Hollow shaft), SSI/BiSS

Order code shaft version:

8 . 5 8 6 3 . X X X X . X X X X

10 by 10

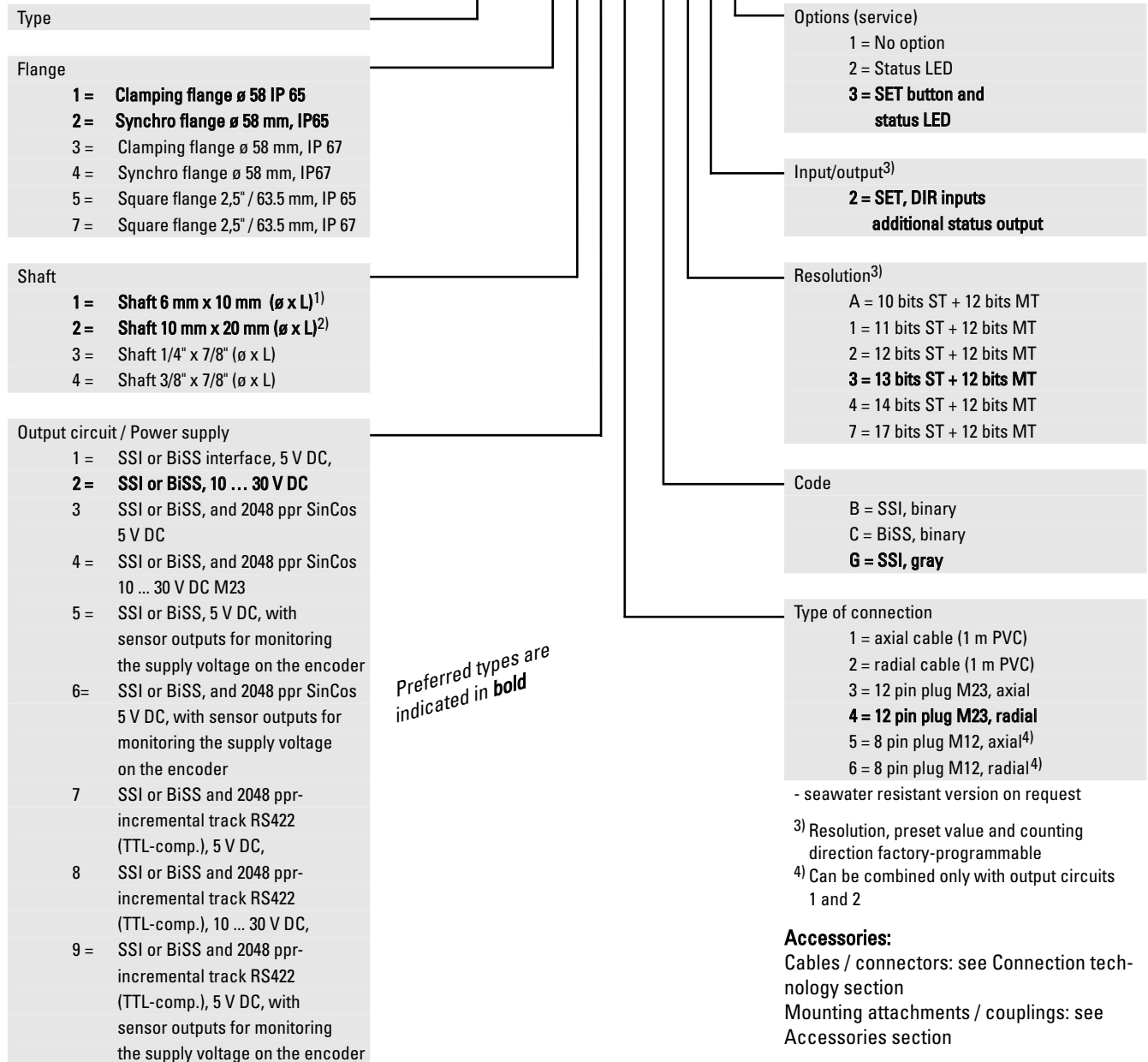

1) Preferred type with flange type 2

2) Preferred type with flange type 1

Rotary Measuring Technology

Absolute encoders, Multiturn, SSI/BiSS

Sendix absolut, Multiturn Type 5863 (Shaft) / 5883 (Hollow shaft), SSI/BiSS

Dimensions hollow shaft version:

Flange with long torque stop

ø 58 mm, M12, M23 connector, cable versions

Flange type 1 and 2 (Drawing with M12 connector)

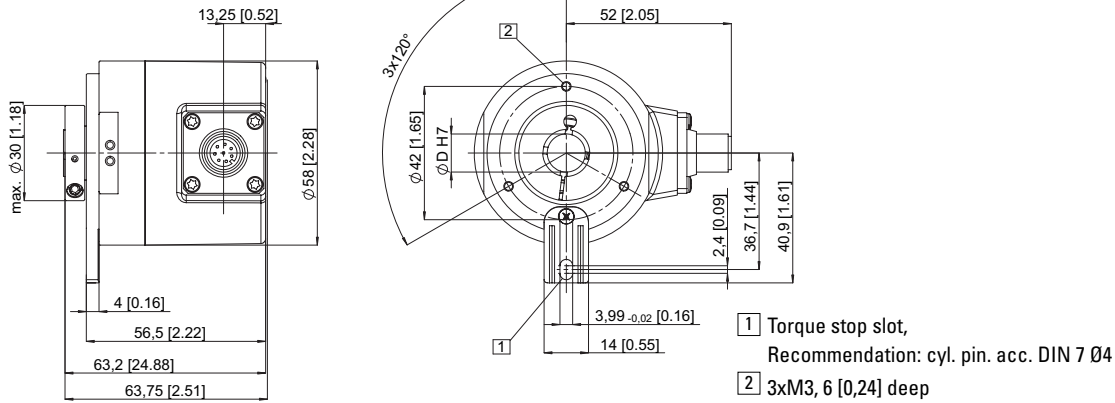

Flange with stator coupling

ø 58 mm, M12, M23 connector, cable versions

Flange type 5 and 6, pitch circle ø 63 mm (Drawing with M23 connector)

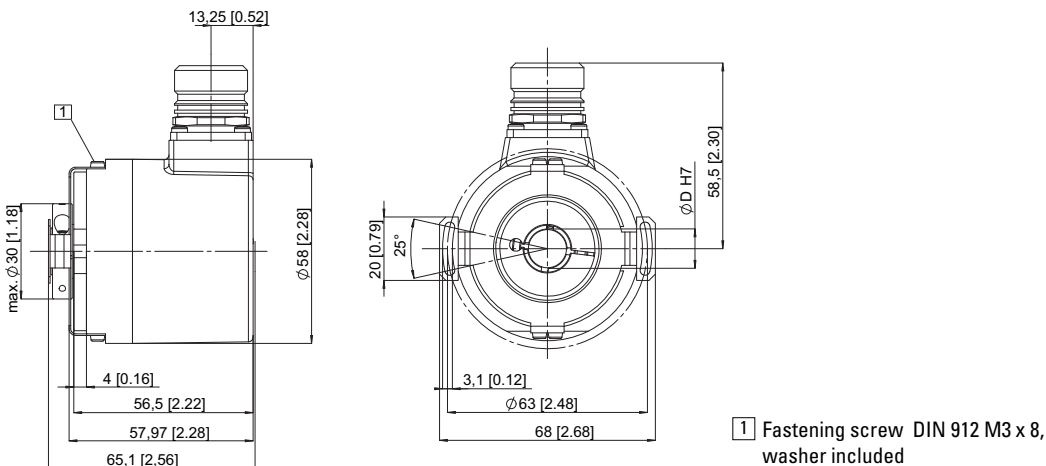

Flange with stator coupling

ø 58 mm, M12, M23 connector, cable versions

Flange type 3 and 4, pitch circle ø 65 mm (Drawing with cable version)

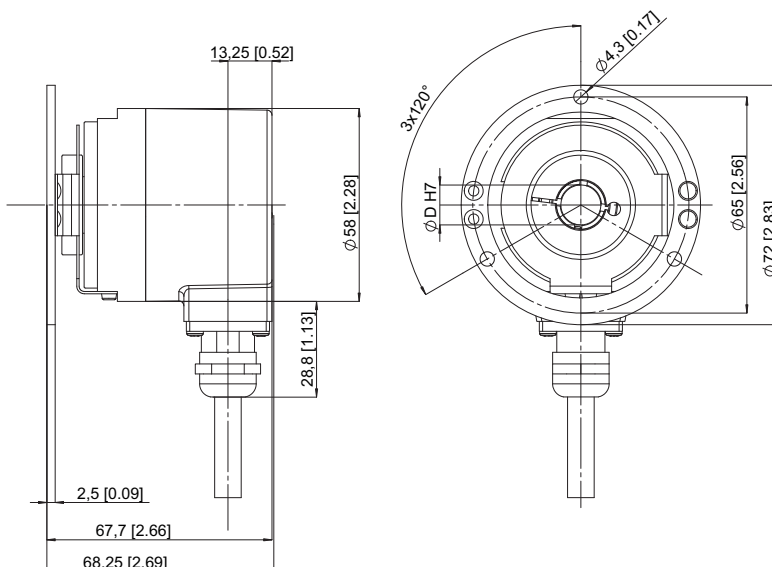

Rotary Measuring Technology

Absolute encoders, Multiturn, SSI/BiSS

Sendix absolut, Multiturn Type 5863 (Shaft) / 5883 (Hollow shaft), SSI/BiSS

Dimensions hollow shaft version:
Flange with long torque stop
ø 58 mm, tangential cable outlet

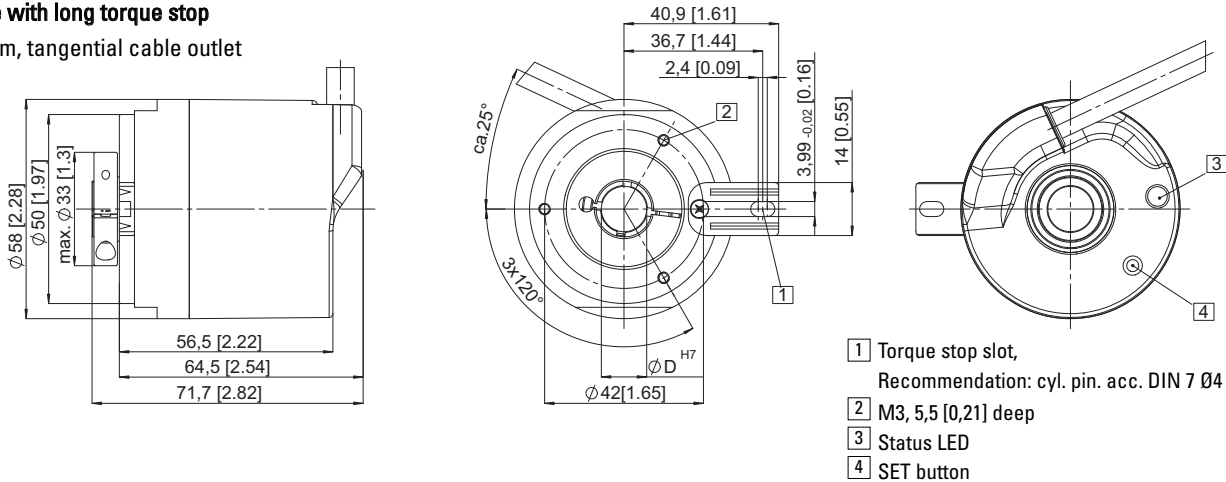

- 1 Torque stop slot, Recommendation: cyl. pin. acc. DIN 7 Ø4
- 2 M3, 5,5 [0,21] deep
- 3 Status LED
- 4 SET button

Order code hollow shaft version:

8 . 5 8 8 3 . X X X X . X X X X

10 by 10

Type		Options (service)
Flange		1 = no option
1 = Flange with torque stop IP 65		2 = status LED
2 = Flange with torque stop IP 67		3 = SET button and status LED
3 = Flange with stator coupling pitch circle ø 65, IP 65		Input/output ³⁾
4 = Flange with stator coupling pitch circle ø 65, IP 67		2 = SET, DIR inputs
5 = Flange with stator coupling pitch circle ø 63, IP 65		additional status output
6 = Flange with stator coupling pitch circle ø 63, IP 67		Resolution ³⁾
Hollow shaft		A = 10 bits ST + 12 bits MT
3 = ø 10 mm		1 = 11 bits ST + 12 bits MT
4 = ø 12 mm		2 = 12 bits ST + 12 bits MT
5 = ø 14 mm		3 = 13 bits ST + 12 bits MT
6 = ø 15 mm (blind hollow shaft)		4 = 14 bits ST + 12 bits MT
8 = ø 9.52 mm [3/8"]		7 = 17 bits ST + 12 bits MT
9 = ø 12.7 mm [1/2"]		Code
	<i>Preferred types are indicated in bold</i>	B = SSI, binary
		C = BiSS, binary
		G = SSI, Gray
Output circuit / Power supply		Type of connection
1 = SSI or BiSS interface, 5 V DC,	7 SSI or BiSS and 2048 ppr-incremental track RS422 (TTL-comp.), 5 V DC,	2 = radial cable (1 m PVC)
2 = SSI or BiSS, 10 ... 30 V DC	8 SSI or BiSS and 2048 ppr-incremental track RS422 (TTL-comp.), 10 ... 30 V DC,	4 = 12 pin plug M23, radial
3 SSI or BiSS, and 2048 ppr SinCos 5 V DC ⁴⁾	9 = SSI or BiSS and 2048 ppr-incremental track RS422 (TTL-comp.), 5 V DC, with sensor outputs for monitoring the supply voltage on the encoder	6 = 8 pin plug M12, radial ⁴⁾
4 = SSI or BiSS, and 2048 ppr SinCos 10 ... 30 V DC M23 ⁴⁾		E = tangential cable outlet (1 m PVC cable)
5 = SSI or BiSS, 5 V DC, with sensor outputs for monitoring the supply voltage on the encoder		- seawater resistant version on request
6 = SSI or BiSS, and 2048 ppr SinCos 5 V DC, with sensor outputs for monitoring the supply voltage on the encoder		³⁾ Resolution, preset value and counting direction factory-programmable
		⁴⁾ Can be combined only with output circuits 1 and 2

Accessories:
Cables / connectors: see Connection technology section
Mounting attachments / couplings: see Accessories section

Rotary Measuring Technology

Absolute encoders, Multiturn, Profibus-DP

Sendix absolut, Multiturn Type 5868 (Shaft) / 5888 (Hollow shaft), Profibus-DP



Mechanical drive



Safety-Lock™



High rotational speed



Temperature
-40° +80°



High IP



High shaft load capacity



Shock/vibration resistant



Magnetic field proof



Short-circuit proof



Reverse polarity protection

Reliable

- Increased ability to withstand vibration and installation errors. Eliminates machine downtime and repairs.

Sturdy "Safety-Lock™ Design" bearing structure

- Fewer components and connection points increase the operational reliability

OptoASIC technology with highest integration density (Chip-on-Board)

- Remains sealed, even in the roughest environments, ensures highest safety against field breakdowns

Resistant die cast housing and protection up to IP 67

- Can be used in a wide temperature range without additional expense

Wide temperature range

- Immediate recognition of error-free bus operation



Sendix[®] absolut 

Fast

- Fast data availability while reducing the load on the bus and the control

Intelligent functions like the transmission of speed, acceleration or exiting a working area

- Fast, simple and error-free connection

Versatile

- Up-to-the minute field bus performance in the application

Profibus-DPV0 with the current encoder profile supports Class 1 and Class 2 Enhanced programming possibilities

- Connection options

Bus cover with M12 connector or cable connection

- Fast start-up with pre-defined GSD file

A variety of scaling options for the most diverse applications
16 bit singleturn resolution
12 bit multiturn resolution
Comprehensive diagnostics, programmable to Class 2

- Reliable installation in a wide diversity of mounting situations

Extensive choice of proven mounting options

- also available in seawater resistant version, certified acc. to salt-spray test IEC 68-2-11 => 672 hours.

Mechanical characteristics:

Max. speed without shaft seal (IP 65) up to 70 °C: 9 000 min⁻¹, continuous 7 000 min⁻¹

Max. speed without shaft seal (IP 65) up to Tmax: 7 000 min⁻¹, continuous 4 000 min⁻¹

Max. speed with shaft seal (IP 67) up to 70 °C: 8 000 min⁻¹, continuous 6 000 min⁻¹

Max. speed with shaft seal (IP 67) up to Tmax: 6 000 min⁻¹, continuous 3 000 min⁻¹

Starting torque without shaft seal (IP65): < 0.01 Nm

Starting torque with shaft seal (IP67): < 0.03 Nm

Moment of inertia: Shaft version: 4.0 x 10⁻⁶ kgm²

Hollow shaft version: 7.5 x 10⁻⁶ kgm²

Radial load capacity of shaft: 80 N

Axial load capacity of shaft: 40 N

Weight: approx. 0.57 kg with bus terminal cover

approx. 0.52 kg with fixed connection

Protection acc. to EN 60 529: housing: IP 67, shaft: IP 65, opt. IP 67

EX approval for hazardous areas: optional zone 2 and 22

Working temperature: -40° C ... +80 °C

Materials: Shaft: stainless steel, Flange: aluminium, Housing: die cast zinc

Shock resistance acc. to DIN-IEC 68-2-27: >2500 m/s², 6 ms

Vibration resistance acc. to DIN-IEC 68-2-6: >100 m/s², 55 ... 2000 Hz



- Absolutely safe operation even in strong magnetic fields
- Over 40 years of experience in the field of precision mechanics
- Special gears with specific toothing

Rotary Measuring Technology

Absolute encoders, Multiturn, Profibus-DP

Sendix absolut, Multiturn Type 5868 (Shaft) / 5888 (Hollow shaft), Profibus-DP

General electrical characteristics:

Supply voltage:	10 ... 30 V DC
Current consumption (w/o output load):	24 V DC, max.90 mA
Reverse polarity protection at power supply (U _B):	Yes
Conforms to CE requirements acc. to EN 61000-6-2, EN 61000-6-4 and EN 61000-6-3	
UL certified	File 224618
RoHS compliant acc. to EU guideline 2002/95/EG	

Interface characteristics Profibus-DP

Singleturn resolution (max, scaleable):	1 ... 65536 (16 bits), default scale value is set to 8192 (13 bits)
Total resolution:	28 Bit (scaleable 1 ... 2 ²⁸ steps)
Number of Revolutions:	4096 (12 bits), (scaleable 1 ... 4096)
Code:	Binary
Interface:	Specification according to Profibus-DP 2.0 Standard (DIN 19245 Part 3) RS-485 driver galvanically isolated.

Profibus Encoder-Profile V1.1

The PROFIBUS-DP device profile describes the functionality of the communication and the user-specific component within the PROFIBUS field bus system. For encoders, the encoder profile is definitive. Here the individual objects are defined independent of the manufacturer. Furthermore, the profiles offer space for additional manufacturer-specific functions; this means that PROFIBUS-compliant device systems can be used now with the guarantee that they are ready for the future too.

The following parameters can be programmed:

- Direction of rotation
- Scaling
- Number of steps per revolution
- Number of revolutions
- Total resolution over Singleturn/Multiturn
- Preset value
- Diagnostics mode

Terminal assignment with terminal box:

Signal :	BUS IN				BUS OUT			
	B	A	0 V	+ V	0 V	+ V	B	A
Pin :	1	2	3	4	5	6	7	8

Shield must be connected to the cable gland (with the contact surface as large as possible).

Terminal assignment M12 connector version:

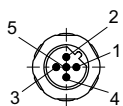

Bus in:

Signal :	–	BUS-A	–	BUS-B	Shield
Pin:	1	2	3	4	5

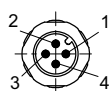

Power supply:

Signal :	U _B	–	0 V	–
Pin:	1	2	3	4

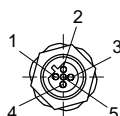

Bus out:

Signal :	BUS_VDC ¹⁾	BUS-A	BUS_GND ¹⁾	BUS-B	Shield
Pin:	1	2	3	4	5

¹⁾ for powering an external Profibus-DP terminating resistor

SET control button (zero or defined value, option)

Protected against accidental activation, can only be pushed in with the tip of a ball pen or similar.

Diagnostics LED (yellow)

LED on with:

optical sensor path faulty (code error, LED error), low voltage and over-temperature

Protocol: Profibus Encoder Profile V1.1 Class 1 and Class 2 with manufacturer-specific enhancements

Baud rate: 12 Mbits/s

Node address: 1 ... 127 (set by rotary switches / software configurable)

Termination switchable: Set by DIP switches

The following parameters can be configured

- Position 16/32 Bit
- Speed UPM or Unit/s (16/32) Bit

The following functionality is integrated:

- Galvanic isolation of the bus stage with DC/DC converter
- Line driver acc. to RS 485 max. 12 MB
- Address programmable via DIP switches
- Diagnostics LED
- Full Class 1 and Class 2 functionality

Rotary Measuring Technology

Absolute encoders, Multiturn, Profibus-DP

Sendix absolut, Multiturn Type 5868 (Shaft) / 5888 (Hollow shaft), Profibus-DP

Dimensions shaft version

With removable bus terminal cover

ø 58 mm, Synchro flange

Flange type 2 and 4 (Drawing with cable version)

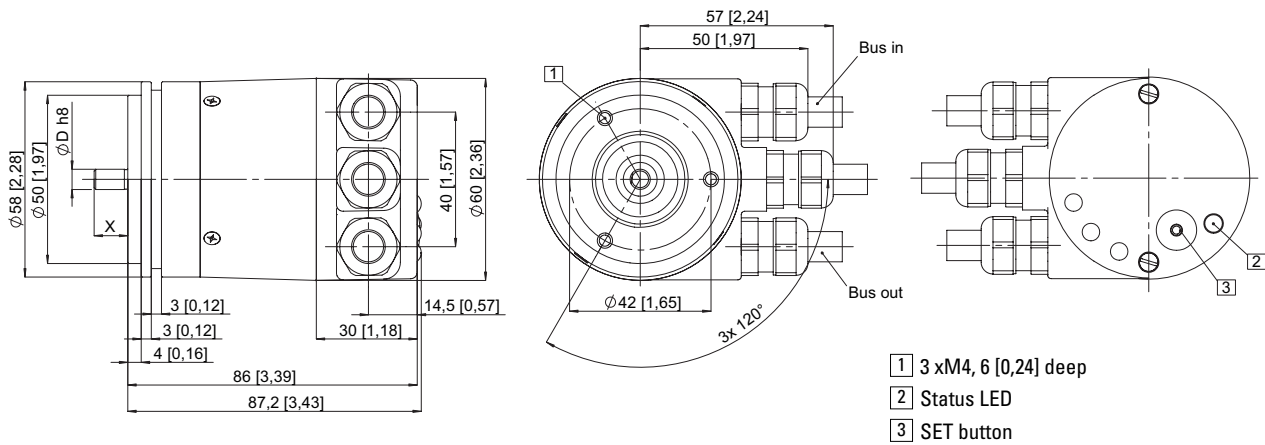

ø 58 mm, Clamping flange

Flange type 1 and 3 (Drawing with 2 x M12 connector)

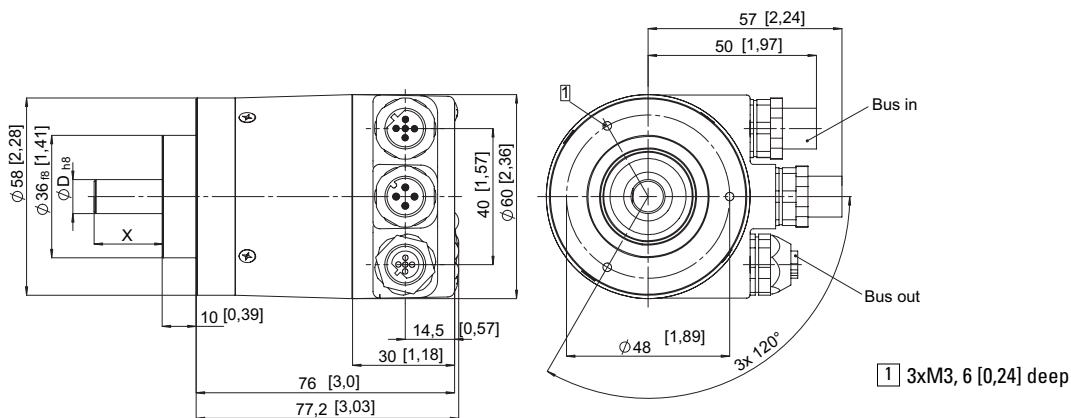

63.5 mm □, Square flange

Flange type 5 and 7 (Drawing with cable version)

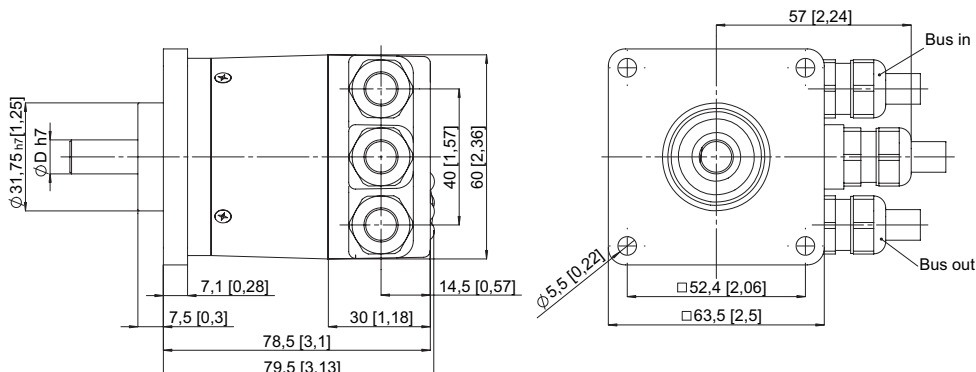

Rotary Measuring Technology

Absolute encoders, Multiturn, Profibus-DP

Sendix absolut, Multiturn Type 5868 (Shaft) / 5888 (Hollow shaft), Profibus-DP

Order code shaft version:

8 . 5 8 6 8 . X X X X . X X 1 X 10 by 10

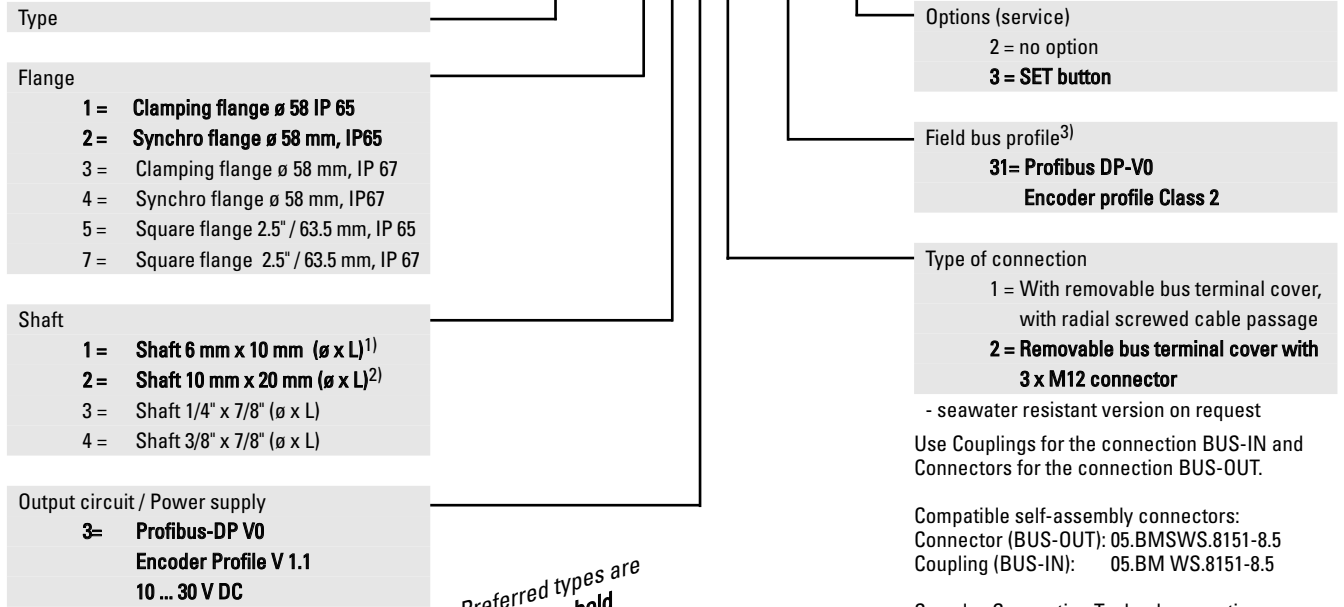

¹⁾ Preferred type with flange type 2
²⁾ Preferred type with flange type 1

Preferred types are indicated in bold

- seawater resistant version on request
Use Couplings for the connection BUS-IN and Connectors for the connection BUS-OUT.

Compatible self-assembly connectors:
Connector (BUS-OUT): 05.BMSWS.8151-8.5
Coupling (BUS-IN): 05.BM.WS.8151-8.5

See also Connection Technology section

Accessories:

- Cables and connectors, also pre-assembled, can be found in Connection Technology section
- Mounting attachments and couplings can be found in Accessories section

Rotary Measuring Technology

Absolute encoders, Multiturn, Profibus-DP

Sendix absolut, Multiturn Type 5868 (Shaft) / 5888 (Hollow shaft), Profibus-DP

Dimensions hollow shaft version:

With removable bus terminal cover:

ø 58 mm, Flange with long torque stop

Flange type 1 and 2 (Drawing with 2x M12 connector)

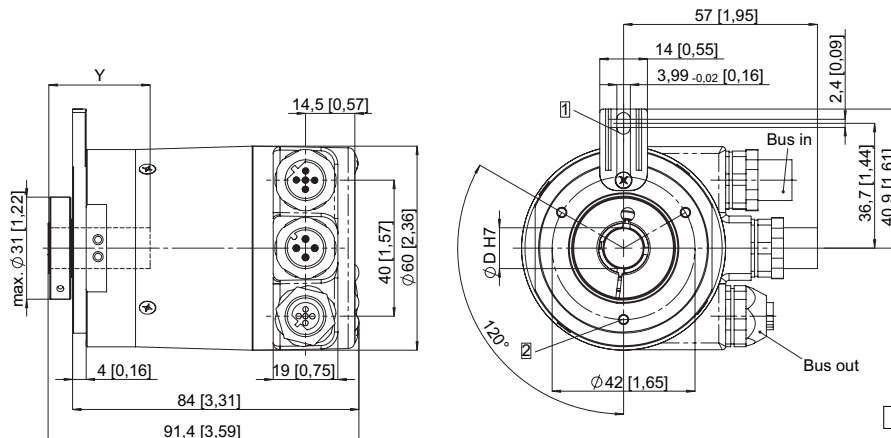

- 1 Torque stop slot,
Recommendation: cyl. pin. acc. DIN 7 Ø4
- 2 3xM3, 5.5 [0.21]deep

ø 58 mm, Flange with stator coupling

Flange type 5 and 6, pitch circle ø 63 mm (Drawing with cable versions)

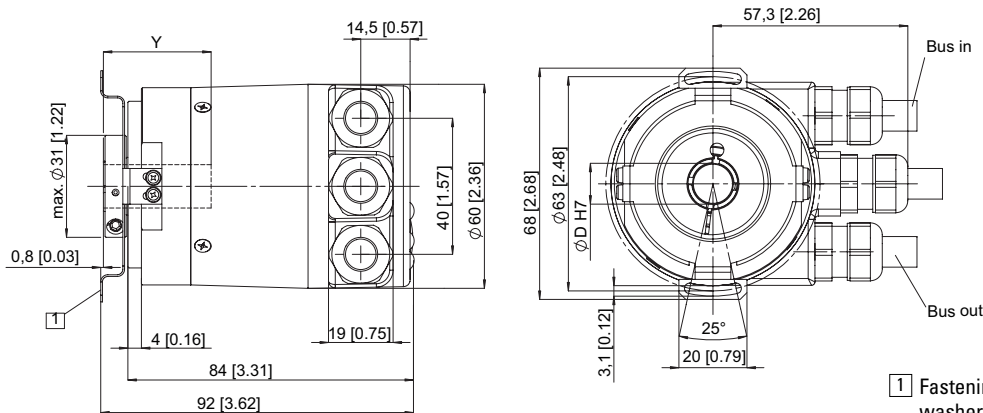

- 1 Fastening screw DIN 912 M3 x 8,
washer included

ø 58 mm, Flange with stator coupling

Flange type 3 and 4, pitch circle ø 65 mm (Drawing with 2x M12 connector)

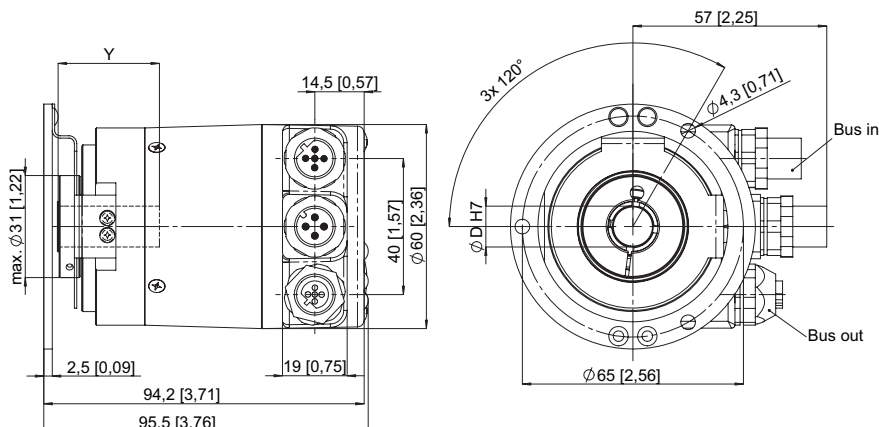

Y: Depth for blind
hollow shaft: 30 mm

Rotary Measuring Technology

Absolute encoders, Multiturn, Profibus-DP

Sendix absolut, Multiturn Type 5868 (Shaft) / 5888 (Hollow shaft), Profibus-DP

Order code hollow shaft version:

8 . 5 8 8 8 . X X X X . X X 1 X



- Type
- Flange
 - 1 = Flange with torque stop IP 65
 - 2 = Flange with torque stop IP 67
 - 3 = Flange with stator coupling pitch circle ø 65, IP 65
 - 4 = Flange with stator coupling pitch circle ø 65, IP 67
 - 5 = Flange with stator coupling pitch circle ø 63, IP 65**
 - 6 = Flange with stator coupling pitch circle ø 63, IP 67
- Hollow shaft
 - 3 = Blind hollow shaft ø 10 mm
 - 4 = Blind hollow shaft ø 12 mm**
 - 5 = Blind hollow shaft ø 14 mm
 - 6 = Blind hollow shaft ø 15 mm
 - 8 = Blind hollow shaft ø 9.52 mm [3/8"]
 - 9 = Blind hollow shaft ø 12.7 mm [1/2"]
- Output circuit / Power supply
 - 3 = Profibus-DP V0 Encoder Profile V 1.1 10 ... 30 V DC**

- Options (service)
 - 2 = no option
 - 3 = SET button**

- Field bus profile³⁾
 - 31 = Profibus DP-V0 Encoder profile Class 2**

- Type of connection
 - 1 = With removable bus terminal cover, with radial screwed cable passage
 - 2 = Removable bus terminal cover with 3 x M12 connector**

- seawater resistant version on request
Use Couplings for the connection BUS-IN and Connectors for the connection BUS-OUT.

Compatible self-assembly connectors:
Connector (BUS-OUT): 05.BMSWS.8151-8.5
Coupling (BUS-IN): 05.BM WS.8151-8.5

- Accessories:**
- Cables and connectors, also pre-assembled, can be found in Connection Technology section
 - Mounting attachments and couplings can be found in Accessories section

Preferred types are indicated in bold

Rotary Measuring Technology

Absolute encoders, Multiturn, CANopen/CANlift

Sendix absolut, Multiturn Type 5868 (Shaft) / 5888 (Hollow shaft), CANopen/CANlift



Mechanical drive



Safety-Lock™



High rotational speed



Temperature -40° + 80°



High IP



High shaft load capacity



Shock/vibration resistant



Magnetic field proof



Short-circuit proof



Reverse polarity protection

Reliable

- **Increased ability to withstand vibration and installation errors. Eliminates machine downtime and repairs.**

Sturdy "Safety-Lock™ Design" bearing structure

- **Fewer components and connection points increase the operational reliability**

OptoASIC technology with highest integration density (Chip-on-Board)

- **Remains sealed, even in the roughest environments, ensures highest safety against field breakdowns**

Resistant die cast housing and protection up to IP 67

- **Can be used in a wide temperature range without additional expense**

Wide temperature range

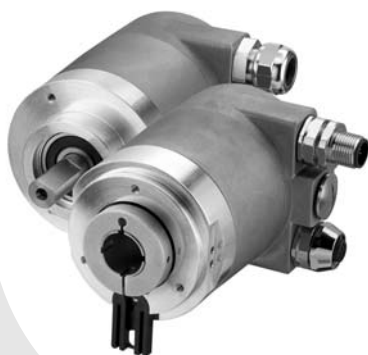

Sendix® absolut    2/22



Fast

- **Genuine time-synchronous position detection of several axes**
Extended CAN Sync Mode with real-time position acquisition
- **Fast data availability while reducing the load on the bus and the control**
Intelligent functions like the transmission of speed, acceleration or exiting a working area
- **Fast, simple and error-free connection**

Versatile

- **Latest field bus performance for the applications**

CANopen, CANlift with the latest profiles

- **The suitable connection variant for every specific case**

Bus terminal cover with M12 connector or cable connection or fixed connection with M12, M23 or D-Sub connector, also easy point-to-point connections

- **Position, Speed, acceleration, working area - The user decides which information is to be available in real-time**

Variable PDO mapping in the memory

- **Quick and error-free start-up, without setting any switches**

Node address, baud rate and termination can be programmed via the bus

- **Reliable mounting in the most various installation cases**

Comprehensive and proven mounting possibilities

Hollow shaft version: Direct mounting also on large diameter standard shafts
Blind hollow shaft up to 15 mm

- also available in **seawater resistant** version, certified acc. to salt-spray test IEC 68-2-11 => 672 hours.

Mechanical characteristics:

Max. speed without shaft seal (IP 65) up to 70 °C:	9 000 min ⁻¹ , continuous 7 000 min ⁻¹
Max. speed without shaft seal (IP 65) up to Tmax:	7 000 min ⁻¹ , continuous 4 000 min ⁻¹
Max. speed with shaft seal (IP 67) up to 70 °C:	8 000 min ⁻¹ , continuous 6 000 min ⁻¹
Max. speed with shaft seal (IP 67) up to Tmax:	6 000 min ⁻¹ , continuous 3 000 min ⁻¹
Starting torque without shaft seal (IP65):	< 0.01 Nm
Starting torque with shaft seal (IP67):	< 0.03 Nm
Moment of inertia:	Shaft version: 4.0 x10 ⁻⁶ kgm ² Hollow shaft version: 7.5 x10 ⁻⁶ kgm ²
Radial load capacity of shaft:	80 N
Axial load capacity of shaft:	40 N
Weight:	approx. 0.57 kg with bus terminal cover approx. 0.52 kg with fixed connection
Protection acc. to EN 60 529:	housing: IP 67, shaft: IP 65, opt. IP 67
EX approval for hazardous areas:	optional zone 2 and 22
Working temperature:	-40° C ... +80° C ¹⁾
Materials:	Shaft: stainless steel, Flange: aluminium, Housing: die cast zinc, Cable: PVC
Shock resistance acc. to DIN-IEC 68-2-27:	>2500 m/s ² , 6 ms
Vibration resistance acc. to DIN-IEC 68-2-6:	>100 m/s ² , 55 ... 2000 Hz

1) Cable versions: -30 °C ... + 75 °C



- Absolutely safe operation even in strong magnetic fields
- Over 40 years of experience in the field of precision mechanics
- Special gears with specific toothing

Rotary Measuring Technology

Absolute encoders, Multiturn, CANopen/CANlift

Sendix absolut, Multiturn Type 5868 (Shaft) / 5888 (Hollow shaft), CANopen/CANlift

General electrical characteristics:

Supply voltage:	10 ... 30 V DC
Current consumption (w/o output load):	24 V DC, max. 65 mA
Reverse polarity protection at power supply (Ub):	Yes
Conforms to CE requirements acc. to EN 61000-6-2, EN 61000-6-4 and EN 61000-6-3	
UL certified	File 224618
RoHS compliant acc. to EU guideline 2002/95/EG	

Interface characteristics CANopen/CANlift:

Singleturn resolution (max, scaleable):	1 ... 65536 (16 bits), default scale value is set to 8192 (13 bits)
Total resolution:	1 ... 268 435 456 (28 Bit) Default: 25 Bit
Code:	Binary
Interface:	CAN High-Speed according ISO 11898, Basic- and Full-CAN CAN Specification 2.0 B
Protocol:	CANopen profile DS 406 V3.1 with manufacturer-specific add-on's

SET control button (zero or defined value, option)

Protected against accidental activation, can only be pushed in with the tip of a ball pen or similar.

Diagnostic LED (yellow)

LED on with:
optical sensor path faulty (code error, LED error), low voltage and over-temperature

	or CANlift profile DS 417 V1.1
Baud rate:	10 ... 1000 kbits/s (set by DIP switches/software configurable)
Node address:	1 ... 127 (set by rotary switches / software configurable)
Termination switchable:	Set by DIP switches Software configurable

General information about CAN/CANlift

The CANopen encoders of the 5868 series support the latest CANopen communication profile according to DS 301 V4.02. In addition, device-specific profiles like the encoder profile DS 406 V3.1 and the profile DS 417 V1.1 (for lift applications) are available. The following operating modes may be selected: Polled Mode, Cyclic Mode, Sync Mode and a High Resolution Sync Protocol. Moreover, scale factors, preset values, limit switch values and many other additional parameters can be programmed via the CAN-Bus. When switching the device on, all parameters, which have been saved on an EEPROM to protect them against power failure, are loaded again. The following output values may be combined in a freely variable way as PDO (PDO mapping): **position, speed, acceleration**, as well

as the status of the working area.

As a price-effective variant, encoders with a connector or a cable connection are available, for which the device address and baud rate are modified by means of software. The models with bus terminal cover and integrated T-shaped coupler allow a particularly easy installation: bus and power supply are connected very simply thanks to M12 connectors; the device address is set by means of two hexadecimal rotary switches. Furthermore, another DIP switch allows setting the baud rate and switching on a termination resistor. Three LED's located on the back indicate the operating or fault status of the CAN bus, as well as the status of an internal diagnostic.

CANopen Communication Profile V4.02

Among others, the following functionality is integrated:
Class C2 Functionality
NMT Slave • Heartbeat Protocol • High Resolution Sync Protocol
Identity Object • Error Behaviour Object • Variable PDO Mapping self-start programmable (Power on to operational)
3 Sending PDO's • Node address, baud rate and CANbus Programmable termination

CANopen Encoder Profile V3.1

The following parameters can be programmed:

- Event mode
- Units for speed selectable (Steps/Sec or RPM)
- Factor for speed calculation (e.g. measuring wheel periphery)
- Integration time for speed value of 1...32
- 2 work areas with 2 upper and lower limits and the corresponding output states
- Variable PDO mapping for position, speed, acceleration, work area status
- Extended failure management for position sensing with integrated temperature control
- User interface with visual display of bus and failure status - 3 LED's
- optional - 32 CAM's programmable
- Customer-specific memory - 16 Bytes

CANopen Lift Profile DS 417 V1.1

Among others, the following functionality is integrated:

- Car Position Unit
- 2 virtual devices
- 1 virtual device delivers the position in absolute measuring steps (steps)
- 1 virtual device delivers the position as an absolute travel information in mm
- Lift number programmable
- Independent setting of the node address in relation with the CAN identifier
- Factor for speed calculation (e.g. measuring wheel periphery)
- Integration time for speed value of 1...32
- 2 work areas with 2 upper and lower limits and the corresponding output states
- Variable PDO mapping for position, speed, acceleration, work area status
- Extended failure management for position sensing with integrated temperature control
- User interface with visual display of bus and failure status - 3 LED's

All profiles stated here: **Key-features**

The object 6003h "Preset" is assigned to an integrated key, accessible from the outside "Watchdog-controlled" device

Rotary Measuring Technology

Absolute encoders, Multiturn, CANopen/CANlift

Sendix absolut, Multiturn Type 5868 (Shaft) / 5888 (Hollow shaft), CANopen/CANlift

Terminal assignment:

Bus terminal cover with terminal box (type of connection 1)

Direction:	OUT					IN				
Signal:	CAN Ground	CAN_Low (-)	CAN_High (+)	0 Volt power supply	+UB power supply	0 V power supply	+UB power supply	CAN_Low (-)	CAN_High (+)	CAN Ground
Abbreviation:	CG	CL	CH	0 V	+V	0 V	+V	CL	CH	CG

Terminal assignment:

Cable connection (type of connection A) and D-SUB-9 connector (type of connection K)

Direction:	IN				
Signal:	0 V power supply	+UB power supply	CAN_Low (-)	CAN_High (+)	CAN Ground
Abbreviation:	0 V	+V	CL	CH	CG
Cable colour:	WH	BN	YE	GN	GY
D-SUB 9	6	9	2	7	3

Terminal assignment:

Bus terminal cover with 2 x M12 connector (type of connection 2, F or J)

Direction:	OUT					IN				
Signal:	CAN Ground	CAN_Low (-)	CAN_High (+)	0 Volt power supply	+UB power supply	0 V power supply	+UB power supply	CAN_Low (-)	CAN_High (+)	CAN Ground
Abbreviation:	CG	CL	CH	0 V	+V	0 V	+V	CL	CH	CG
M23 PIN assignment	3	2	7	10	12	10	12	2	7	3
M12 PIN assignment	1	5	4	3	2	3	2	5	4	1

Bus in and out M23:

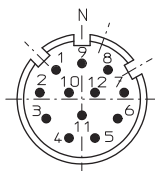

Corresponding mating connector:
8.0000.5012.0000

Bus out:

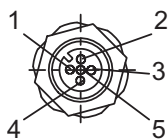

Corresponding mating connector:
05.BS-8151-0/9

Bus in:

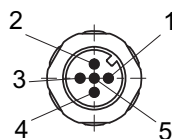

Corresponding mating connector:
05.B-8151-0/9

Terminal assignment:

M23 (type of connection I) or M12 (type of connection E) connector

Direction:	IN				
Signal:	0 V power supply	+UB power supply	CAN_Low (-)	CAN_High (+)	CAN Ground
Abbreviation:	0 V	+V	CL	CH	CG
M23 PIN assignment	10	12	2	7	3
M12 PIN assignment	3	2	5	4	1

Bus in M23:

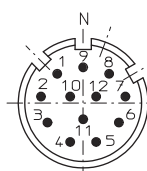

Corresponding mating connector:
8.0000.5012.0000

Bus in M12:

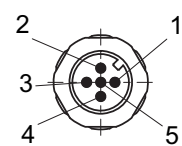

Corresponding mating connector:
05.B-8151-0/9

Rotary Measuring Technology

Absolute encoders, Multiturn, CANopen/CANlift

Sendix absolut, Multiturn Type 5868 (Shaft) / 5888 (Hollow shaft), CANopen/CANlift

Dimensions shaft version

With removable bus terminal cover

ø 58 mm, Synchro flange

Flange type 2 and 4 (Drawing with cable version)

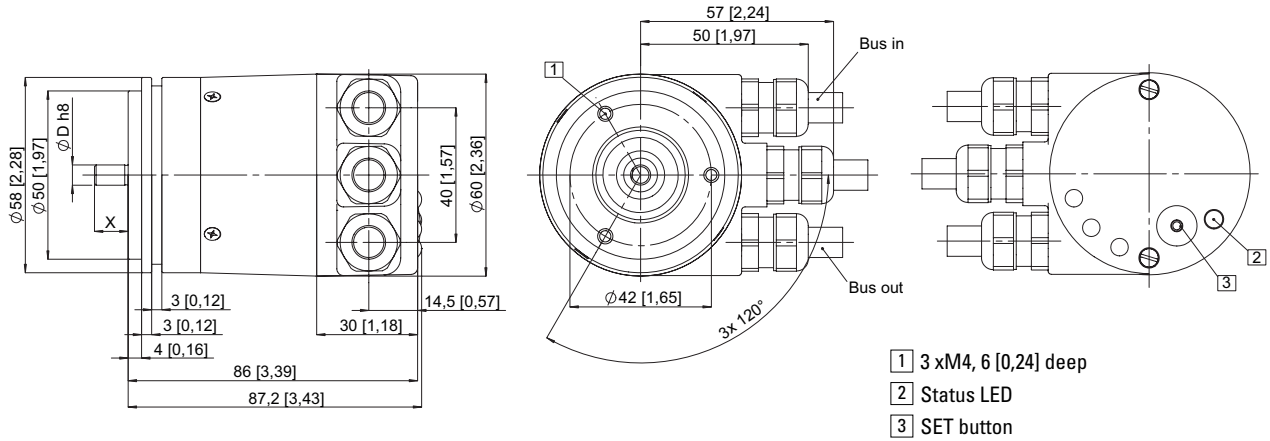

ø 58 mm, Clamping flange

Flange type 1 and 3 (Drawing with 2 x M12 connector)

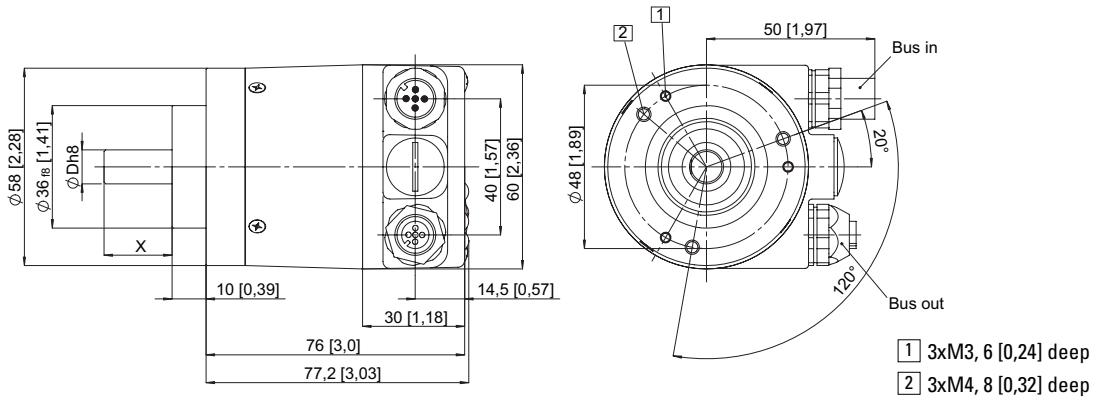

63.5 mm □, Square flange

Flange type 5 and 7 (Drawing with cable version)

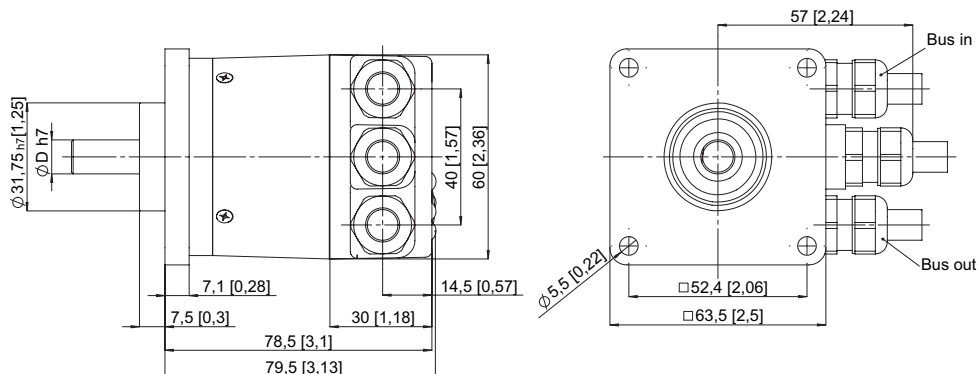

Rotary Measuring Technology

Absolute encoders, Multiturn, CANopen/CANlift

Sendix absolut, Multiturn Type 5868 (Shaft) / 5888 (Hollow shaft), CANopen/CANlift

Dimensions shaft version

With fixed connection

ø 58 mm, Synchro flange

Flange type 2 and 4 (Drawing with M23 connector)

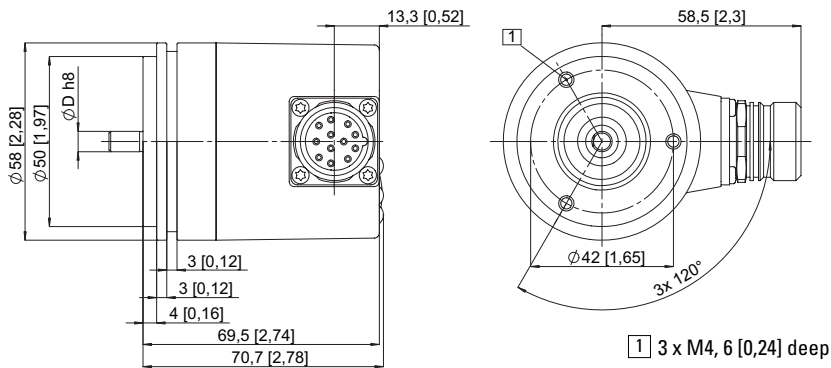

ø 58 mm, Synchro flange

Flange type 2 and 4 (Drawing with D-SUB connector)

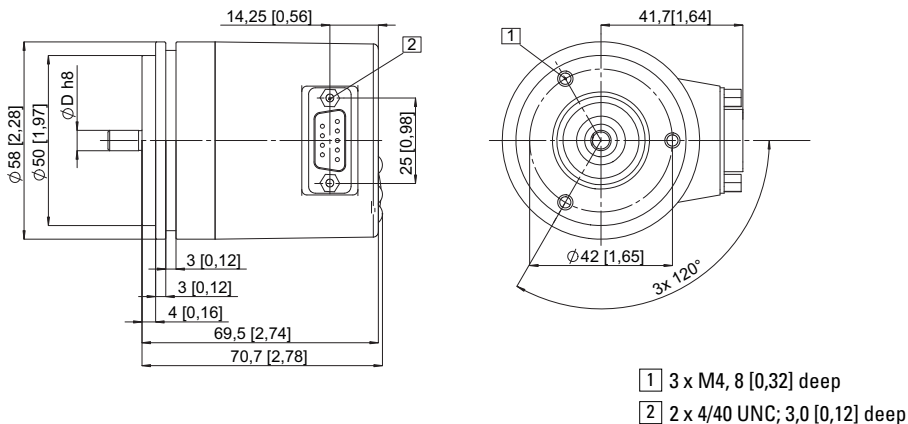

63.5 mm □, Square flange

Flange type 5 and 7 (Drawing with 2 x M23 connector)

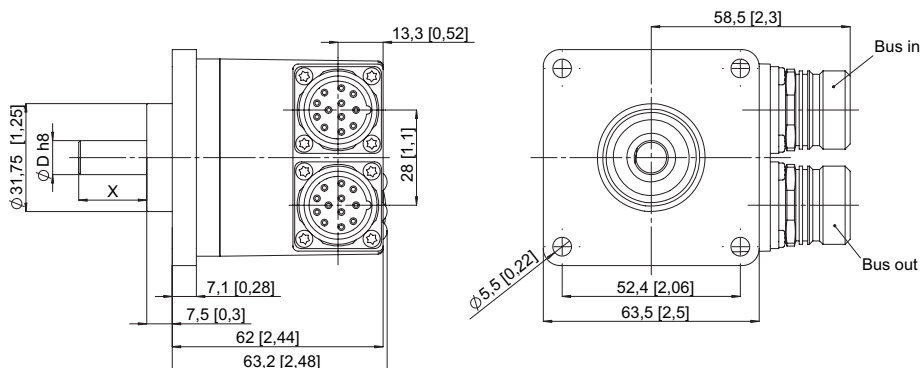

Rotary Measuring Technology

Absolute encoders, Multiturn, CANopen/CANlift

Sendix absolut, Multiturn Type 5868 (Shaft) / 5888 (Hollow shaft), CANopen/CANlift

Dimensions shaft version:

With fixed connection

ø 58 mm, Clamping flange

Flange type 1 and 3 (Drawing with 1 x M12 connector)

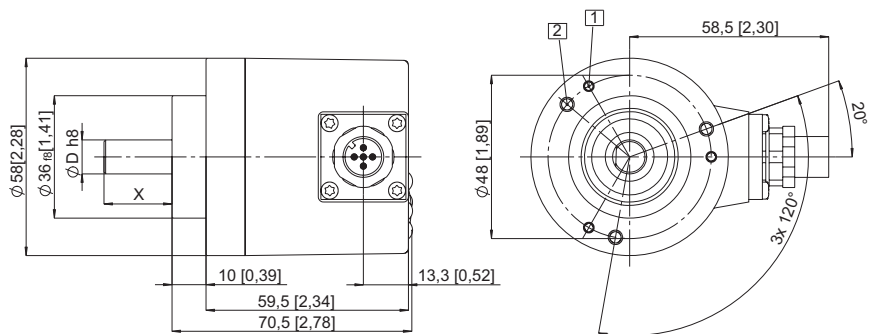

- 1 3xM3, 6 [0,24] deep
- 2 3xM4, 8 [0,32] deep

ø 58 mm, Synchro flange

Flange type 2 and 4 (Drawing with 2 x M12 connector)

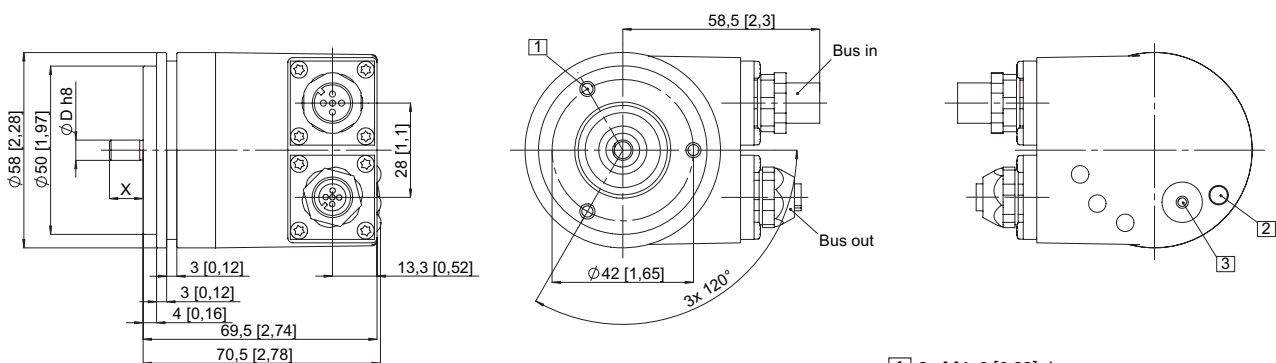

- 1 3 xM4, 8 [0,32] deep
- 2 Status LED
- 3 SET button

ø 58 mm, Clamping flange

Flange type 1 and 3 (Drawing with cable version)

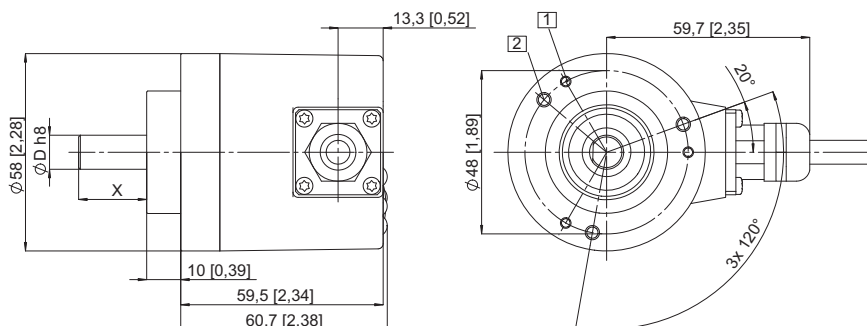

- 1 3xM3, 6 [0,24] deep
- 2 3xM4, 8 [0,32] deep

Rotary Measuring Technology

Absolute encoders, Multiturn, CANopen/CANlift

Sendix absolut, Multiturn Type 5868 (Shaft) / 5888 (Hollow shaft), CANopen/CANlift

Order code shaft version:

8 . 5 8 6 8 . X X X X . X X 1 X

10 by 10

Type		Options (service) 2 = no option 3 = SET button
Flange	<ul style="list-style-type: none"> 1 = Clamping flange \varnothing 58 IP 65 2 = Synchro flange \varnothing 58 mm, IP65 3 = Clamping flange \varnothing 58 mm, IP 67 4 = Synchro flange \varnothing 58 mm, IP67 5 = Square flange 2.5" / 63.5 mm, IP 65 7 = Square flange 2.5" / 63.5 mm, IP 67 	Field bus profile ³⁾ 21 = CANopen Encoder-Profile DS 406 V3.1 22 = CANlift DS 417 V1.01
Shaft	<ul style="list-style-type: none"> 1 = Shaft 6 mm x 10 mm (\varnothing x L)¹⁾ 2 = Shaft 10 mm x 20 mm (\varnothing x L)²⁾ 3 = Shaft 1/4" x 7/8" (\varnothing x L) 4 = Shaft 3/8" x 7/8" (\varnothing x L) 	Type of connection 1 = With removable bus terminal cover, with radial screwed cable passage 2 = Removable bus terminal cover with M12 connector A = Fixed connection without bus terminal cover, with radial cable (2 m PVC) E = Fixed connection without bus terminal cover, with 1 x M12 radial connector F = Fixed connection without bus terminal cover, with 2 x M12 radial connector I = Fixed connection without bus terminal cover, with 1 x M23 radial connector J = Fixed connection without bus terminal cover, with 2 x M23 radial connector K = Fixed connection without bus terminal cover, with 1 x D-SUB 9-pin connector
Output circuit / Power supply	<ul style="list-style-type: none"> 2 = CANopen DS 301 V4.0 10 ... 30 V DC 5³⁾ = CANopen DS301 V4.0 with 2048 ppr incremental track (TTL-compatible), 10 ... 30 V DC 	- seawater resistant version on request ³⁾ CAN parameters can also be factory-preset

Preferred types are indicated in bold

¹⁾ Preferred type with flange type 2
²⁾ Preferred type with flange type 1
³⁾ only with type of connection 2

Accessories:

- Cables and connectors, also pre-assembled, can be found in the chapter Counting Technology
- Mounting attachments and couplings can be found in the Chapter Accessories

Supplementary details incremental track:

Characteristics:

Output driver:	RS 422 (TTL compatible)
Permissible load/channel:	\pm 20 mA
Signal level High:	typ. 3.8 V
Low:	typ. 1.3 V
Short-circuit proof outputs:	yes (short-circuit proof to 0 V or output, when supply voltage is correctly applied)
Resolution	2048 ppr

Terminal assignment incremental track:

Signal:	A	\bar{A}	B	\bar{B}	0
Pin:	1	2	3	4	5

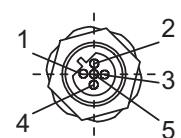

Corresponding mating connector:
05.BMSWS 8151-8.5

Rotary Measuring Technology

Absolute encoders, Multiturn, CANopen/CANlift

Sendix absolut, Multiturn Type 5868 (Shaft) / 5888 (Hollow shaft), CANopen/CANlift

Dimensions hollow shaft version (blind hollow shaft):

With removable bus terminal cover

ø 58 mm, Flange with long torque stop

Flange type 1 and 2 (Drawing with 2x M12 connector)

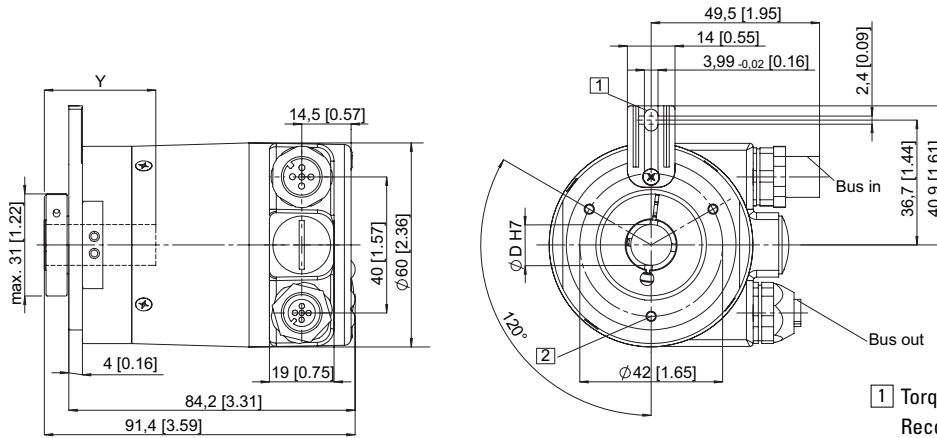

- 1 Torque stop slot,
Recommendation: cyl. pin. acc. DIN 7 04
- 2 3xM3, 5.5 [0.21] deep

ø 58 mm, Flange with stator coupling

Flange type 5 and 6, pitch circle ø 63 mm (Drawing with cable versions)

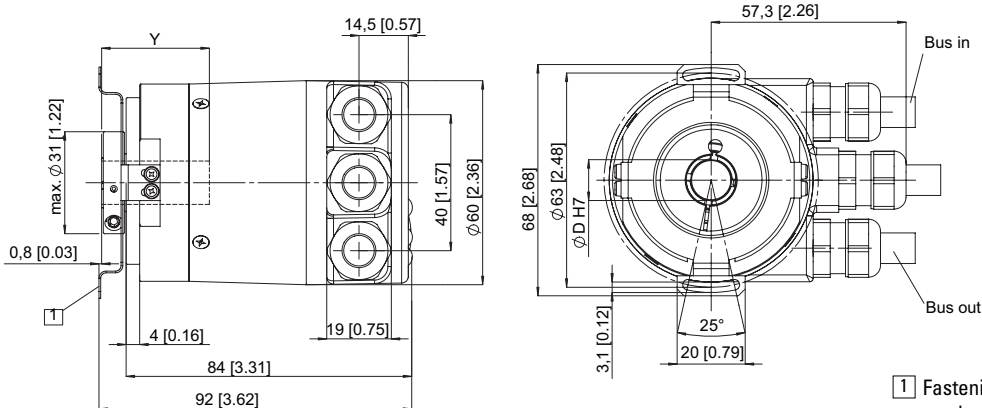

- 1 Fastening screw DIN 912 M3 x 8,
washer included

ø 58 mm, Flange with stator coupling

Flange type 3 and 4, pitch circle ø 65 mm (Drawing with 2x M12 connector)

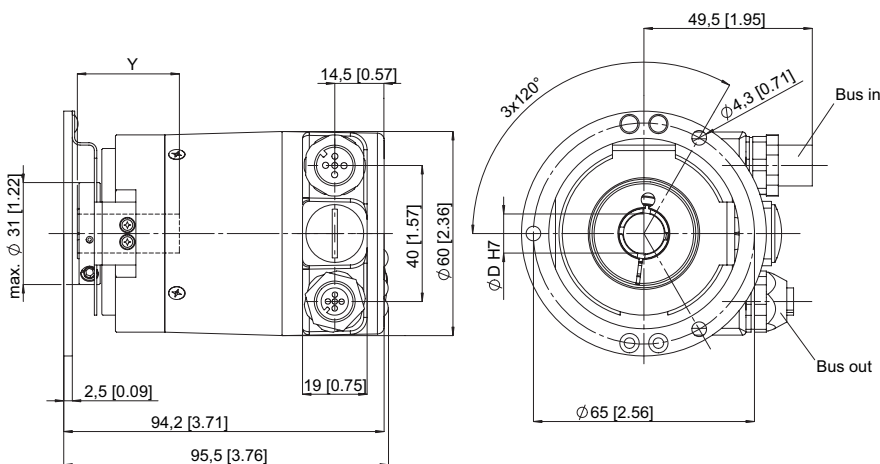

Y: Depth for blind
hollow shaft: 30 mm

Rotary Measuring Technology

Absolute encoders, Multiturn, CANopen/CANlift

Sendix absolut, Multiturn Type 5868 (Shaft) / 5888 (Hollow shaft), CANopen/CANlift

Dimensions hollow shaft version (blind hollow shaft):

With fixed connection

ø 58 mm, Flange with long torque stop

Flange type 1 and 2 (Drawing with M23 connector)

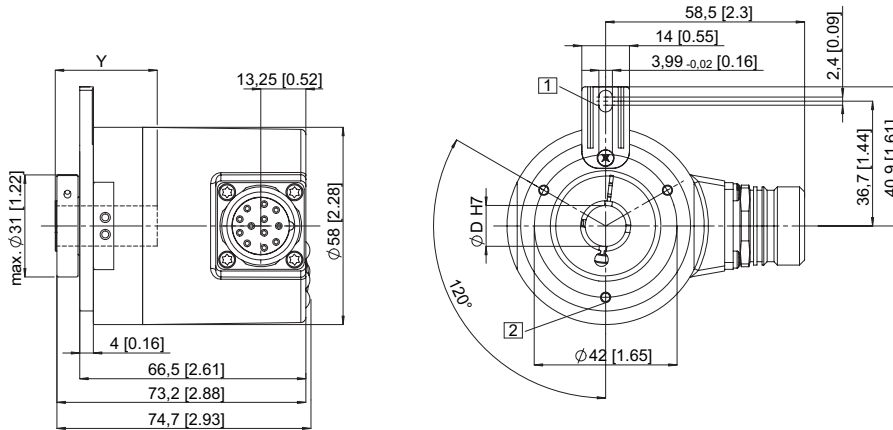

- 1 Torque stop slot,
Recommendation: cyl. pin. acc. DIN 7 Ø4.0
- 2 3xM3, 5.5 [0.21] deep

ø 58 mm, Flange with long torque stop

Flange type 1 and 2 (Drawing with D-SUB connector)

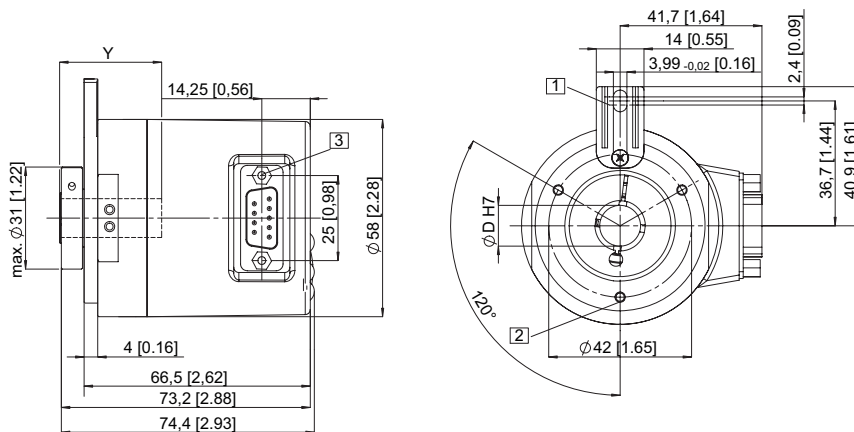

- 1 Torque stop slot,
Recommendation: cyl. pin. acc. DIN 7 Ø4.0
- 2 3xM3, 5.5 [0.21] deep
- 3 2 x 4/40 UNC; 3.0 [0.21] deep

ø 58 mm, Flange with stator coupling

Flange type 3 and 4, pitch circle ø 65 mm (Drawing with 2xM23 connector)

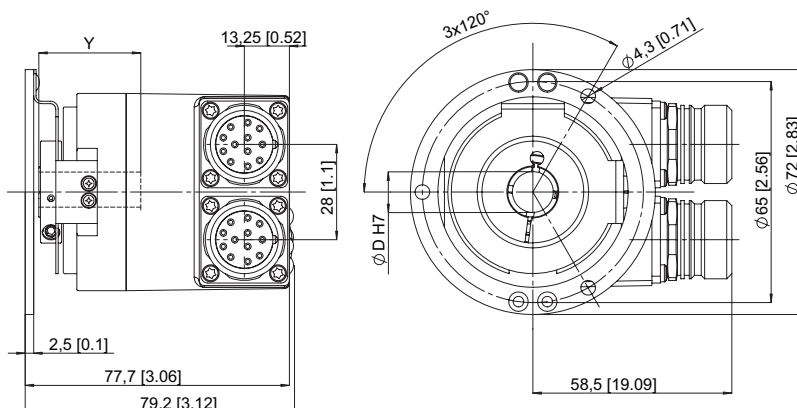

Y: Depth for blind
hollow shaft: 30 mm

Rotary Measuring Technology

Absolute encoders, Multiturn, CANopen/CANlift

Sendix absolut, Multiturn Type 5868 (Shaft) / 5888 (Hollow shaft), CANopen/CANlift

Dimensions hollow shaft version (blind hollow shaft):

With fixed connection

ø 58 mm, Flange with stator coupling

Flange type 5 and 6, pitch circle ø 63 mm (Drawing with M12 connector)

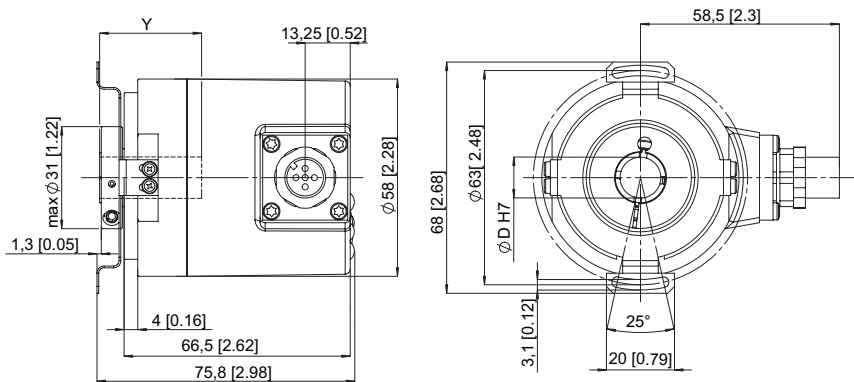

ø 58 mm, Flange with long torque stop

Flange type 1 and 2 (Drawing with 2xM12 connector)

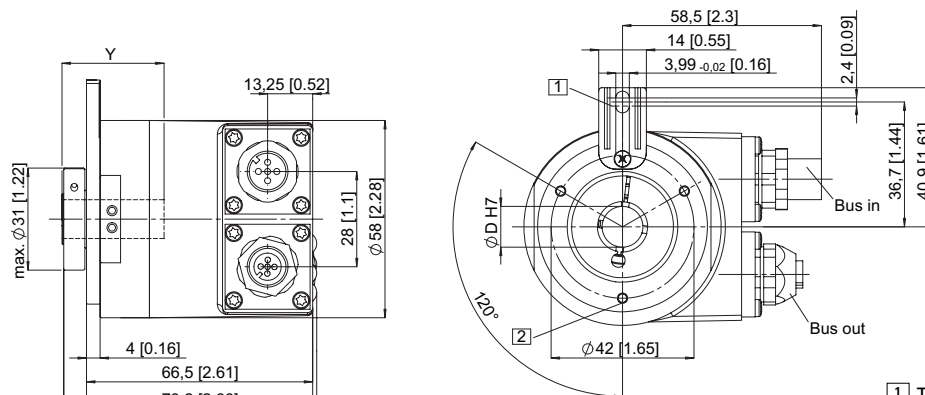

- 1 Torque stop slot,
Recommendation: cyl. pin. acc. DIN 7 Ø4.0
- 2 3xM3, 5.5 [0.21] deep

ø 58 mm, Flange with stator coupling

Flange type 3 and 4, pitch circle ø 65 mm (Drawing with 2x M12 connector)

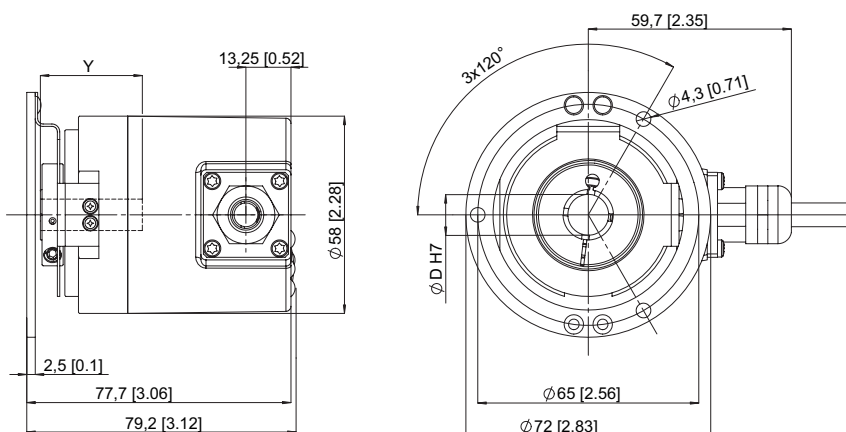

**Y: Depth for blind
hollow shaft: 30 mm**

Rotary Measuring Technology

Absolute encoders, Multiturn, CANopen/CANlift

Sendix absolut, Multiturn Type 5868 (Shaft) / 5888 (Hollow shaft), CANopen/CANlift

Order code hollow shaft version:

8 . 5 8 8 8 . X X X X . X X 1 X

10 by 10

Type

Flange

- 1 = Flange with torque stop IP 65
- 2 = Flange with torque stop IP 67
- 3 = Flange with stator coupling pitch circle ø 65, IP 65
- 4 = Flange with stator coupling pitch circle ø 65, IP 67
- 5 = Flange with stator coupling pitch circle ø 63, IP 65**
- 6 = Flange with stator coupling pitch circle ø 63, IP 67

Hollow shaft

- 3 = Blind hollow shaft ø 10 mm
- 4 = Blind hollow shaft ø 12 mm**
- 5 = Blind hollow shaft ø 14 mm
- 6 = Blind hollow shaft ø 15 mm
- 8 = Blind hollow shaft ø 9.52 mm [3/8"]
- 9 = Blind hollow shaft ø 12.7 mm [1/2"]

Output circuit / Power supply

- 2 = CANopen DS 301 V4.0 10 ... 30 V DC**
- 5¹⁾ = CANopen DS301 V4.0 with 2048 ppr incremental track (TTL-compatible), 10 ... 30 V DC**

Preferred types are indicated in bold

Options (service)

- 2 = no option
- 3 = SET button**

Field bus profile³⁾

- 21 = CANopen Encoder-Profile DS 406 V3.1**
- 22 = CANlift DS 417 V1.01

Type of connection

- 1 = With removable bus terminal cover, with radial screwed cable passage
- 2 = Removable bus terminal cover with M12 connector**
- A = Fixed connection without bus terminal cover, with radial cable (2 m PVC)
- E = Fixed connection without bus terminal cover, with 1 x M12 radial connector
- F = Fixed connection without bus terminal cover, with 2 x M12 radial connector
- I = Fixed connection without bus terminal cover, with 1 x M23 radial connector
- J = Fixed connection without bus terminal cover, with 2 x M23 radial connector
- K = Fixed connection without bus terminal cover, with 1 x D-SUB 9-pin connector

- seawater resistant version on request

¹⁾ only with type of connection 2

³⁾ CAN parameters can also be factory-preset

Accessories:

- Cables and connectors, also pre-assembled, can be found in the chapter Counting Technology
- Mounting attachments and couplings can be found in the Chapter Accessories

Supplementary details incremental track:

Characteristics:

Output driver:	RS 422 (TTL compatible)
Permissible load/channel:	± 20 mA
Signal level High:	typ. 3.8 V
Low:	typ. 1.3 V
Short-circuit proof outputs:	yes (short-circuit proof to 0 V or output, when supply voltage is correctly applied)
Resolution	2048 ppr



Terminal assignment incremental track:

Signal:	A	\bar{A}	B	\bar{B}	0
Pin:	1	2	3	4	5

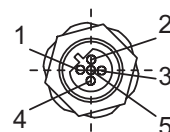

Corresponding mating connector:
05.BMSWS 8151-8.5

Rotary Measuring Technology

Absolute encoders, Multiturn, Ether CAT

Sendix absolut, Multiturn Type 5868 (Shaft) / 5888 (Hollow shaft), EtherCAT

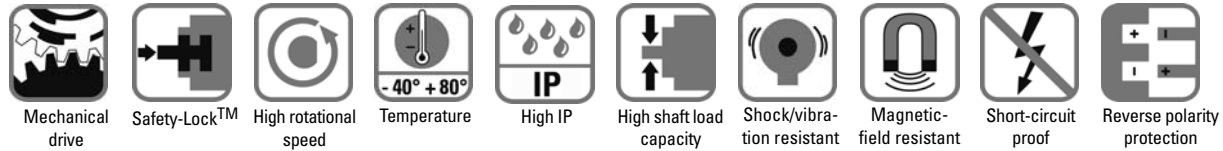

Reliable

- **Increased resistance against vibrations and installation errors. Eliminates machine downtime and repairs.**
Sturdy bearing construction 'Safety-Lock™ Design'
- **Fewer components and connection points increase the operational reliability**
OptoASIC technology with very high integration density (Chip-on-Board)
- **Remains sealed, even in the roughest environments, ensures the highest safety against field breakdowns**
Resistant die-cast housing and protection up to IP 67
- **Can be used in a wide temperature range without additional charge**
wide temperature range (-40 °C ... +80 °C).



Fast

- **Time-synchronous position detection of several axes**
Distributed clock for real-time position detection
- **Fast data availability with reduced loading on the bus and controller**
Intelligent functions such as transmission of speed/velocity, acceleration or leaving a working area
- **Fast, simple, error-free connection**
Bus terminal cover with 3 x M12 connectors

Versatile

- **Up-to-the minute fieldbus performance in the CoE application**
CAN over Ethernet
- **Whether position, speed/velocity, acceleration or working area – the user decides, which information is available in real-time.**
PDO mapping in the memory
- **Fast, error-free start-up – no need to set switches**
All parameters can be programmed via the bus
- **Reliable installation in a wide diversity of mounting situations**
Extensive choice of proven mounting options
- **Numerous special functions**
Temperature monitoring, operating time, customer data (e.g. installation location)
- **also available in seawater resistant version, certified acc. to salt-spray test IEC 68-2-11 => 672 hours.**

Mechanical characteristics:

Max. speed without shaft seal (IP 65) up to 70 °C:	9 000 min ⁻¹ , continuous 7 000 min ⁻¹
Max. speed without shaft seal (IP 65) up to Tmax:	7 000 min ⁻¹ , continuous 4 000 min ⁻¹
Max. speed with shaft seal (IP 67) up to 70 °C:	8 000 min ⁻¹ , continuous 6 000 min ⁻¹
Max. speed with shaft seal (IP 67) up to Tmax:	6 000 min ⁻¹ , continuous 3 000 min ⁻¹
Starting torque without shaft seal (IP65):	< 0.01 Nm
Starting torque with shaft seal (IP67):	Shaft version: < 0.05 Nm Hollow shaft version: <0.03 Nm
Moment of inertia:	Shaft version: 3.0 x10 ⁻⁶ kgm ² Hollow shaft version: 7.5 x10 ⁻⁶ kgm ²
Radial load capacity of shaft:	80 N
Axial load capacity of shaft:	40 N
Weight:	approx. 0.54 kg
Protection acc. to EN 60 529:	housing: IP 67, shaft: IP 65, opt. IP 67
EX approval for hazardous areas:	optional zone 2 and 22
Working temperature:	-40 °C ... +80 °C
Materials:	Shaft: stainless steel, Flange: aluminium, Housing: die cast zinc
Shock resistance acc. to DIN-IEC 68-2-27:	>2500 m/s ² , 6 ms
Vibration resistance acc. to DIN-IEC 68-2-6:	>100 m/s ² , 55 ... 2000 Hz



- Absolutely safe operation even in strong magnetic fields
- Over 40 years of experience in the field of precision mechanics
- Special gears with specific toothings

Rotary Measuring Technology

Absolute encoders, Multiturn, Ether CAT

Sendix absolut, Multiturn Type 5868 (Shaft) / 5888 (Hollow shaft), EtherCAT

General electrical characteristics:

Supply voltage:	10 ... 30 V DC
Current consumption (w/o output load):	24 V DC, max. 90 mA
Reverse polarity protection	Yes
at power supply (Ub):	
Conforms to CE requirements acc. to EN 61000-6-2, EN 61000-6-4 and EN 61000-6-3	
UL certified	File 224618
RoHS compliant acc. to EU guideline 2002/95/EG	

Device characteristics:

Singleturn resolution	1 ... 65535 (16 bit), (scaleable: 1 ... 65535)
Default value:	8192 (13 bit)
Total resolution:	scaleable from 1 to 268435456 (28 Bit) 12 Bit Multiturn
Code:	EtherNet Frame binary
Protocol:	EtherNet/EtherCAT

General information about CoE (CAN over EtherCAT)

The EtherCAT encoders of the 58X8 series support the CANopen communication profile according to DS 301. In addition device-specific profiles like the encoder profile DS 406 are available. Scaling, preset values, limit switch values and many other parameters can be programmed via the EtherCAT bus. When switching the device on, all parameters are loaded from an EEPROM, where they were saved to protect them against power-failure. As output values, position, speed, acceleration and temperature as well as the working area state can be combined as PDO (PDO Mapping).

Diagnostic LED (Red)

LED is ON with the following fault conditions:
Sensor error (internal code or LED error), low voltage, over-temperature

Run LED (Green)

LED is ON with the following conditions:
Init-, Preop-, Safeop and Op-State

2 x Link LED (Yellow)

LED is ON with the following conditions (Port A and B)
Link detected

Modes

Freerun, Distributed Clock (cycle time for Sync 0 pulse min. 125 µs or 62.5 µs with restrictions), Sync-Mode

CANopen Encoder Profile CoE (CAN over EtherCAT)

The following parameters are programmable:

- Units for speed selectable (Steps/Sec or RPM)
- Factor for speed calculation (e.g. circumference of measuring wheel)
- Integration time for the speed value from 1 ... 32
- 2 working area with 2 upper and lower limits and the corresponding output states
- PDO mapping of position, speed/velocity, acceleration and working area
- Extended error management for position sensing with integrated temperature control
- User interface with visual display of bus and fault status – 4 LEDs
- Alarm and warning messages

Terminal assignment bus:

(Type of connection 2, D-coded):

Direction:	Port A				Port B			
Signal:	Transmit data+	Receive data+	Transmit data-	Receive data-	Transmit data+	Receive data+	Transmit data-	Receive data-
Abbreviation:	TxD+	RxD+	TxD-	RxD-	TxD+	RxD+	TxD-	RxD-
M12 PIN-connection:	1	2	3	4	1	2	3	4

Port A and B

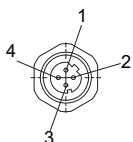

Terminal assignment power supply:

M12 connector

Signal:	+UB Power supply	n.c.	0 V	n.c.
Abbreviation:	+UB	-	0 V	-
M12 PIN-connection	1	2	3	4

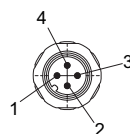

Bus connection

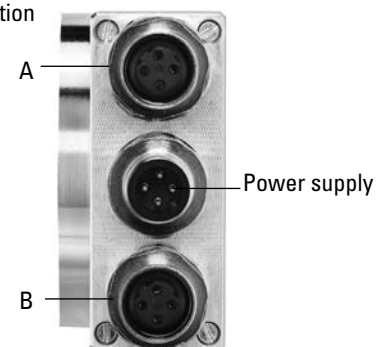

Rotary Measuring Technology

Absolute encoders, Multiturn, Ether CAT

Sendix absolut, Multiturn Type 5868 (Shaft) / 5888 (Hollow shaft), EtherCAT

Dimensions shaft version:
With removable bus terminal cover:

ø 58 mm, Synchro flange
Flange type 2 und 4

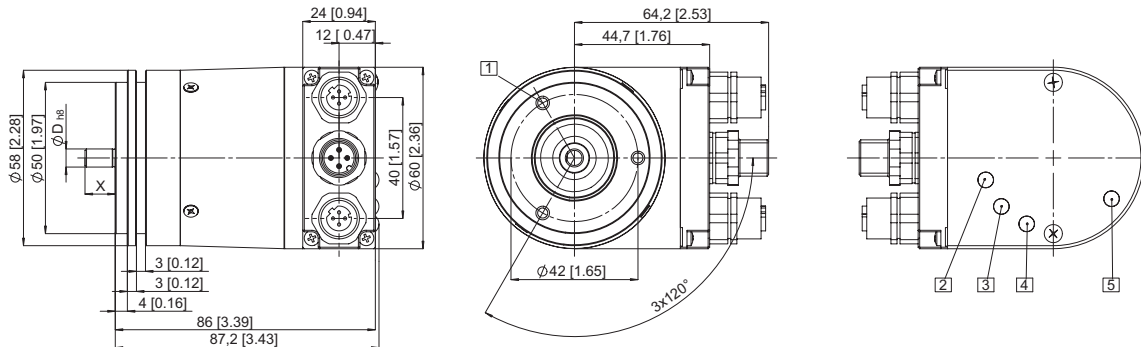

- 1 3xM4, 6,0 [0.24] deep
- 2 Link a, yellow LED
- 3 Link b, yellow LED
- 4 Run, green LED
- 5 Err, red LED

ø 58 mm, Clamping flange
Flange type 1 and 3

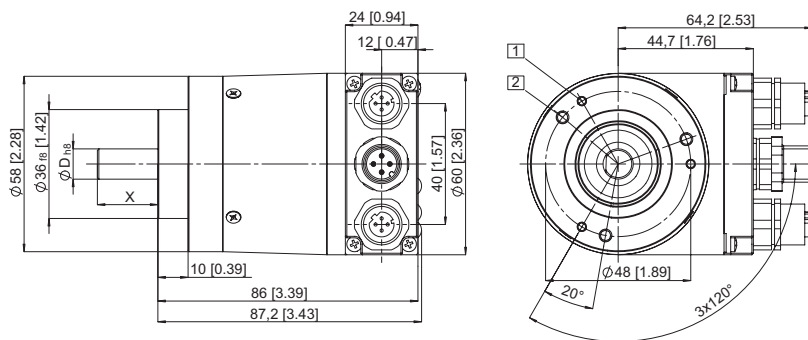

- 1 3xM3, 6,0 [0.24] deep
- 2 3xM4, 8,0 [0.31] deep

63,5 mm, Square flange □
Flange type 5 und 7

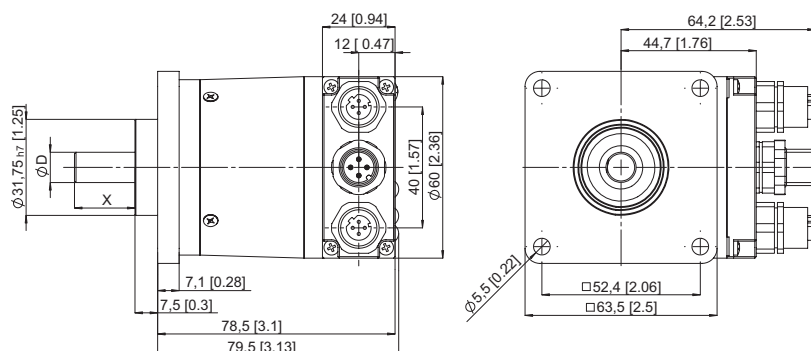

Rotary Measuring Technology

Absolute encoders, Multiturn, Ether CAT

Sendix absolut, Multiturn Type 5868 (Shaft) / 5888 (Hollow shaft), EtherCAT

Order code shaft version:

8 . 5 8 6 8 . X X X X . X X 1 2

Type	
Flange	<p>1 = Clamping flange ø 58 IP 65</p> <p>2 = Synchro flange ø 58 mm, IP65</p> <p>3 = Clamping flange ø 58 mm, IP 67</p> <p>4 = Synchro flange ø 58 mm, IP67</p> <p>5 = Square flange 2.5" / 63.5 mm, IP 65</p> <p>7 = Square flange 2.5" / 63.5 mm, IP 67</p>
Shaft	<p>1 = Shaft 6 mm x 10 mm (ø x L)¹⁾</p> <p>2 = Shaft 10 mm x 20 mm (ø x L)²⁾</p> <p>3 = Shaft 1/4" x 7/8" (ø x L)</p> <p>4 = Shaft 3/8" x 7/8" (ø x L)</p>

Field bus profile
B1 = EtherCAT with CoE
(CAN over EtherNet)

Type of connection
2 = Removable bus terminal cover with 3 x M12 connector
- seawater resistant version on request

Accessories:

- Cables and connectors, also pre-assembled, can be found in the chapter Counting Technology
- Mounting attachments and couplings can be found in the Chapter Accessories

Output circuit / Power supply
B = EtherCAT

1) Preferred type with flange type 2
2) Preferred type with flange type 1

Preferred types are indicated in bold

Dimensions hollow shaft version (blind hollow shaft):

With removable bus terminal cover
ø 58 mm, Flange with torque stop
Flange type 1 and 2

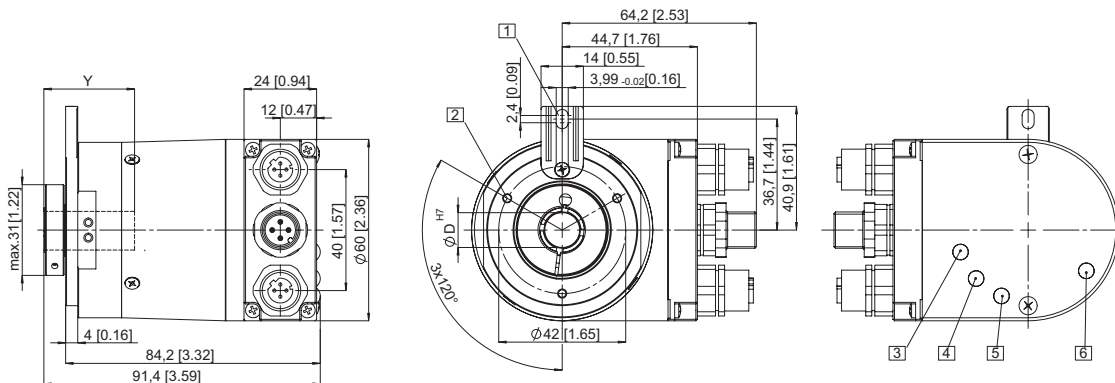

- | | |
|--|----------------------|
| 1 Torque stop slot
Recommendation cyl. pin
DIN 7, ø 4 mm | 4 Link b, yellow LED |
| 2 3xM3, 5,5 [0.21] deep | 5 Run, green LED |
| 3 Link a, yellow LED | 6 Err, red LED |

Rotary Measuring Technology

Absolute encoders, Multiturn, Ether CAT

Sendix absolut, Multiturn Type 5868 (Shaft) / 5888 (Hollow shaft), EtherCAT

Dimensions hollow shaft version (blind hollow shaft):

With removable bus terminal cover

ø 58 mm, Flange with stator coupling
Flange type 5 and 6

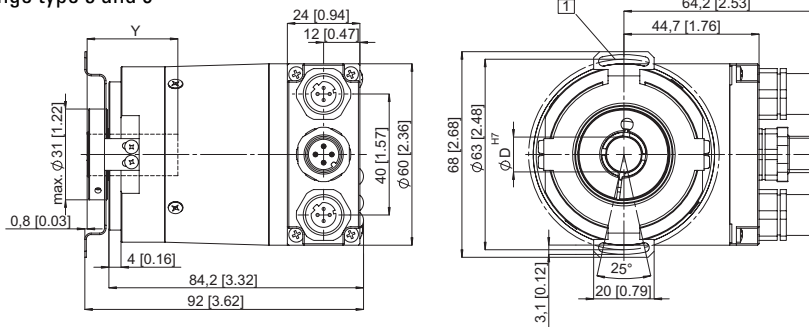

1 Fastening screw DIN 912 M3 x 8, washer included

ø 58 mm, Flange with stator coupling
Flange type 3 and 4

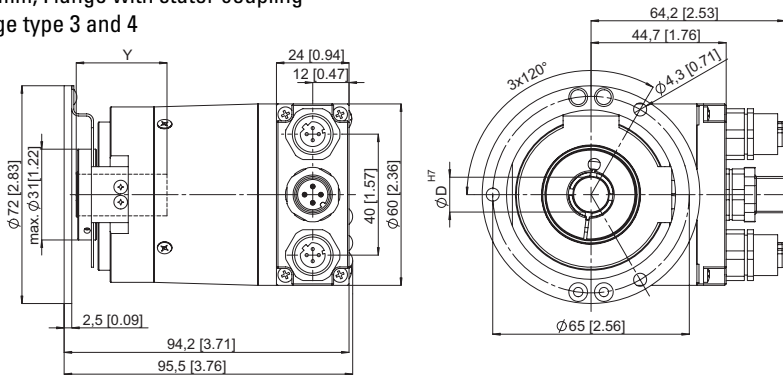

Y: Depth for blind hollow shaft: 30 mm

Order code hollow shaft version:

8 . 5 8 8 8 . X X X X . X X 1 2

Type	
Flange	
1 =	Flange with torque stop IP 65
2 =	Flange with torque stop IP 67
3 =	Flange with stator coupling pitch circle ø 65, IP 65
4 =	Flange with stator coupling pitch circle ø 65, IP 67
5 =	Flange with stator coupling pitch circle ø 63, IP 65
6 =	Flange with stator coupling pitch circle ø 63, IP 67
Hollow shaft	
3 =	Blind hollow shaft ø 10 mm
4 =	Blind hollow shaft ø 12 mm
5 =	Blind hollow shaft ø 14 mm
6 =	Blind hollow shaft ø 15 mm
8 =	Blind hollow shaft ø 9.52 mm [3/8"]
9 =	Blind hollow shaft ø 12.7 mm [1/2"]
Output circuit / Power supply	
B =	EtherCAT
Ex-proof zone 2, 22 on request	

Field bus profile
B1 = EtherCAT with CoE
(CAN over EtherNet)

Type of connection
2 = Removable bus terminal cover with 3 x M12 connector
- seawater resistant version on request

Accessories:
- Cables and connectors, also pre-assembled, can be found in the chapter Counting Technology
- Mounting attachments and couplings can be found in the Chapter Accessories

Preferred types are indicated in bold